

PAPER • OPEN ACCESS

## Comparative study on the chemical and microbiological properties of goat milk pasteurization through serial and circulation systems of ultraviolet method

To cite this article: B Hariono *et al* 2020 *J. Phys.: Conf. Ser.* **1450** 012005

View the [article online](#) for updates and enhancements.



**IOP | ebooks™**

Bringing together innovative digital publishing with leading authors from the global scientific community.

Start exploring the collection—download the first chapter of every title for free.

# Comparative study on the chemical and microbiological properties of goat milk pasteurization through serial and circulation systems of ultraviolet method

B Hariono<sup>1</sup>, R Wijaya<sup>1</sup>, A Bakri<sup>1</sup>

<sup>1</sup> Department of Agricultural Technology, Politeknik Negeri Jember, Jalan Mastrip 164, Jember, Indonesia

Email : rizza.wijaya@polije.ac.id

**Abstract.** The aim of research was to evaluate goat milk pasteurization with exposure of ultraviolet rays serial and circulation systems. The chemical properties parameters measured covering fat content, non-fat dry material content, protein content, and lactose content as well as microbiology testing of Total Plate Count method. Discharge of milk flow was obtained  $4.32 \pm 0.71$  cc/sec. Time needed to fully fill the UV reactor with 230 ml volume was 53.24 second. In serial system showed that chemical properties were not significantly different with 0.5 percent significance level. In the circulation system, with flow rate speed 10 cc/sec with the dosage of 1.56 J/ square cm shows that the treatment 2, 4 and 6 of circulation in the treatment of protein content gave different effect from the control. Other treatments were not different from the control. The treatment with three reactors that arranged in serial was the best treatment with inactivation of microorganism and the dosages of the reactor 1, 2 and, 3 of 0.11; 0.25; 0.51 log cycle and 1.81 J/square cm; 3.62 J/ square cm; 5.43 J/ square cm respectively. D value was 313.49 sec with speed rate and treatment time of  $4.32 \pm 0.71$  cc/sec and 159.72 sec respectively.

## 1. Introduction

Chemical properties of goat milk covered fat content, protein content, lactose content, ash content, non-fat dry material content and the total dry material. Chemical milk, goat milk, was classified into three criteria namely premium, good and standard qualities with the value of protein content, fat content, and dry weight of >3,70%, >4,00%, >13,00%; >3,40-3,70%, 3,50-4,00%, >12,00-13,00% and 3,10-3,40%, 3,25-3,50%, 11,70-12% respectively [1]. The quality of goat milk was the important aspect for the consumer in order to be consumed well and healthy. The milk quality was influenced by some factors such as feed, goat family, lactation, milking procedures and altitude [2]. Livestock maintenance and good handling during milking and post milking was the important factor to produce safe, healthy, whole, and halal goat milk. Microorganism contamination and careless handling reduced the quality of goat milk [3]. Indonesia has established the quality standard for cow's milk but there is no standard for goat milk, so the standard to determine the quality of goat milk according to Thai Agriculture Standard (TAS) No 6006-2008.

Goat milk had high nutritional value because of its unique metabolic properties to be consumed well by human. The characteristics of goat milk included: (1) the color was whiter; (2) smaller fat globular and emulsions with milk; (3) goat milk fat was easier to digest; (4) goat milk contained vitamin in



sufficient or excessive amount, except vitamin C, D, pyridoxine and folic acid [4]. Goat milk had different characteristic compared to cow's milk, that was the color was whiter, the fat was easier to digest the curd protein was softer so that it was possible to be made as a special cheese, contained high mineral (Potassium, phosphorus, vitamin A, vitamin E and B complex) and it was safe to be consumed by people with allergies to cow's milk [5].

The milk contamination by bacteria often happened and caused reduction of its quality. The milk contamination by pathogenic or non-pathogenic bacteria derived from the goat itself, milking equipment, less clean storage space, dust, air, flies, and mishandling by human [6]. Non-thermal food preservation technology was the alternative to be developed in order to get better quality of the product by keeping eye on the food safety factor, maintaining nutritional properties and minimalizing the decrease of taste quality, color and nutritional value. One of the non-thermal technologies was ultraviolet irradiation [7]. Ultraviolet irradiation (UV) reduced the total number of microorganism in food ingredient [8]. The most effective wave length of UV lied in UV-C that was between 200 until 280 nm, especially in 254 nm, while the wave length of 320 nm produced efficiency of almost zero [9].

UV irradiation was successfully implemented into pasteurization of goat milk that reduced the total number of bacteria between 50%-60%, and coliform bacteria of 80%-90% [10]. The treatment as many as 12 times circulation through UV lamp with the dose of  $15.8 \pm 1.6 \text{ mJ/cm}^2$  and turbulent flow rate of 567 liter/hour with 12 times circulation and treatment time of 18 second produced average fat and protein contents of  $4.1 \pm 0.09\%$  and  $2.9 \pm 0.03\%$  respectively as well as inactivated *Listeria monocytogenes* in goat milk as much as 5 log cycle [11]. On inoculated cow's dairy products with *S. Aureus* bacteria and treatment dose of  $5.6 \text{ J/cm}^2$  with volume, sample distance from UV and treatment time of 30 ml, 8 cm, and 180 sec respectively produced inactivation of *S. aureus* as much as 8.55 log-cycle [12].

UV irradiation reduced the total number of microorganism on food ingredient [13]. The most effective wave length of UV lied in UV-C that was between 200-280 nm, especially on 254 nm, while the wave length of 320 nm produced efficiency of almost zero. UV Irradiation affected the DNA of bacteria, virus, fungi, and other microorganism so that prevented the occurrence of reproduction [14].

## 2. Literature review

### 2.1. Serial system

The intensity of UV-C rays was calculated based on the division between UV-C total power and quartz surface area ( $369.29 \text{ cm}^2$ ) to obtain:

$$\text{Intensity} = \frac{\text{Total UV-C per unit (W)}}{\text{Quartz surface area (cm}^2\text{)}} = \frac{10 \text{ W}}{369.29 \text{ cm}^2} = 27.08 \text{ mW/cm}^2 \quad (1)$$

$$\text{Dosage per volume} = \frac{10 \text{ W}}{0.0043 \text{ L/hour}} = 2314.83 \text{ J/L} \quad (2)$$

UV-C dose value based on the Kada specification (USA) is shown in the Table 1.

**Table 1.** Dose valye UV-C actual dan prediction.

Dosage of UV-C actual/prediction <sup>a)</sup>	Dosage value (mW/cm <sup>2</sup> )
Kada (USA) Inc <sup>a)</sup>	30.00
Koutchma <i>et al</i> (2009) <sup>b)</sup>	33.85
Keyser <i>et al</i> (2008) <sup>a)</sup>	27.08

<sup>a)</sup> actual, <sup>b)</sup> prediction

## 2.2. Circulation system

Circulation system used a Diaphragm Brand Yuan TYP pump 2500N; 24 VCD; 0.6 A; 80 psi (0.6 LPM) with a flow rate of 10 cc/second which was set by using a Dawyer flow meter. The treatment time (T) per reactor can be calculated as follows:

$$\text{Treatment Time (T)} = \frac{\text{Reactor volume (L)}}{\text{Flowrate (L/hour)}} = \frac{0.23 \text{ L}}{36 \text{ L/hour}} = 23 \text{ second} \quad (3)$$

UV dosage per two times circulation in the circulation system was calculated from the multiplication between Intensity (I) and Treatment Time (T), therefore it obtained :

$$\text{Dosage} = \text{Intensity (I)} \times \text{Treatment Time (T)}$$

$$= 33.85 \frac{\text{mW}}{\text{cm}^2} \times 46 \text{ s} = 1557.06 \frac{\text{mWs}}{\text{cm}^2} = 1557.06 \frac{\text{mJ}}{\text{cm}^2} \quad (4)$$

## 3. Methodology

### 3.1. Tool and material

In this research the goat milk obtained from Ciampea Bogor and the tools used were UV-C reactor output of Kandid GPH180T5L/10W USA Inc, Reverse Osmosis Brand Deng Yuang TYP-2500N, faucet, flowmeter, “food grade” silicone hose, milkotester, pH meter, conductivity meter and viscosity meter falling ball type.

### 3.2. Research methodology

The research design used was Completely Randomized Design (CRD) with the treatments of serial and circulation systems with 3 replications. The results were analyzed by using ANOVA, if the analysis results showed a significant effect, then LSD (Least Significant Difference) test was performed. The observation was carried out on the chemical properties of milk and microbiologists included; fat content, non-fat dry material content, protein content, lactose content and TPC test.

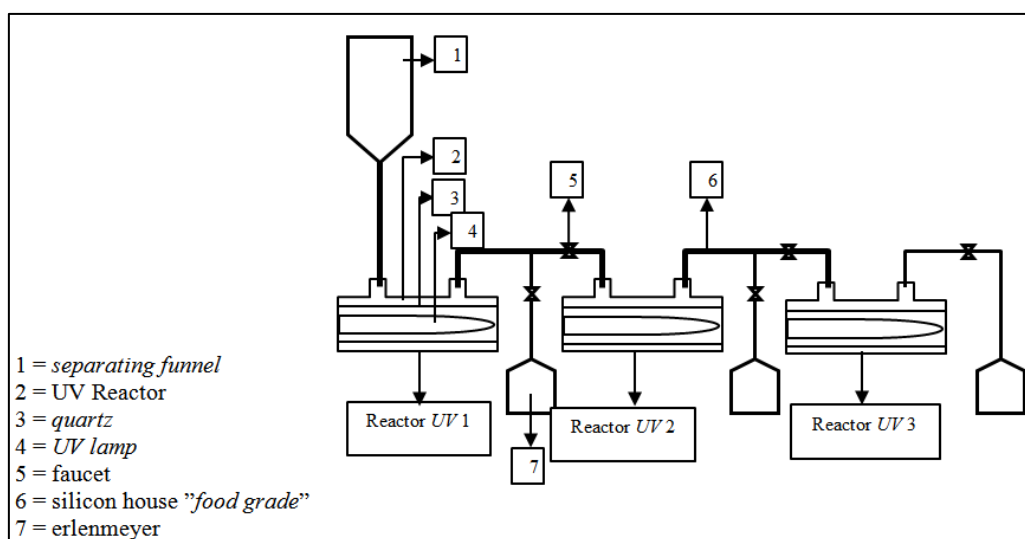
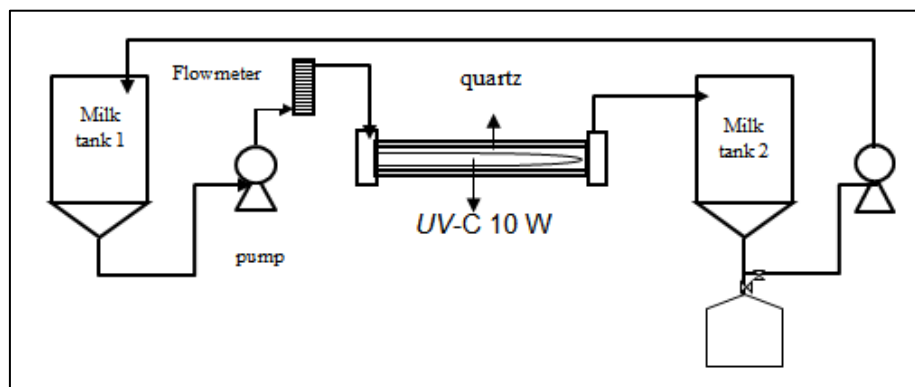

Figure 1. Serial system.

The measurements of fat content, non-fat dry material content, specific gravity, freezing point, protein content and lactose content were done by using Mini Master Milkotester, pH was measured by using a Scoth pH meter, conductivity was measured by using A-Z conductivity meter, viscosity was measured by using falling ball method and specific heat was measured by using Singh and Heldman method [17] dry weight was obtained from the sum of % fat content with % non fats, while the water content was obtained from the reduction between 100% value with % dry weight. TPC test was done by using SNI 01-314-1998 method, in which the number of bacteria were determined by using the cup calculation and to report the analysis results used Standard Plate Count (SPC).

**3.2.1. Serial system.** In the serial system (Figure 1) the goat milk used as much as 1 liter then passed on the UV-C reactors 1, 2 and 3. The testing of chemical properties and microbiologists in each UV reactor used samples taken as much as 100-200 ml. Volumetric method used in measuring flow rate when collecting the milk by using Erlenmeyer as much as 100-200 ml and the time was recorded by using stopwatch. The mean of milk flow rate obtained as much as  $4.32 \pm 0.71$  cc/second, so that the time needed to fill the UV reactor fully with a volume of 230 ml was 53.24 seconds. One cell of bacteria received the exposure of 3 UV reactors with the time exposure of 159.72 seconds.

**3.2.2. Circulation System.** In the circulation system (Figure 2) input and output reactors made from ST 316 material, quartz tube with dose per circulation as much as  $1.56 \text{ J/cm}^2$  and 10 W UV-C lamp of 253.7 nm. The first stage experiment of circulation was started by pouring goat milk as much as 3 liters into the milk tank 1 (temperature of  $27 \pm 1$  °C), then pumped with a flowmeter (the rate was set at 10 gallons per hour or 10.52 cc/second) to the UV reactor inlet until the sample flew to the milk tank 2. After that, the sample in milk tank 2 was re-pumped to the tank 1. The testing of chemical properties and total microorganism of each treatment 2, 4 and 6 of circulation by taking the sample as much as 1 liter for each treatment.



**Figure 2.** Circulation system.

## 4. Experiment and results

### 4.1. Chemical properties of goat milk of serial and circulation systems with a treatment of UV-C 253.7 nm

This UV pasteurization method to obtain the optimum results from the comparison between serial and circulation systems. The chemical properties of goat milk which was given a treatment of UV-C 253.7 nm was shown in the Tables 2 and 3 where numbers followed by the same letters on the same line showed the values that are not significantly different at the test level  $< 0.05$ .

**Table 2.** Chemical characteristics of milk goats treated with the serial system of UV-C 253.7.

Testing	Treatment			
	Control <sup>a</sup>	Reactor 1	Reactor 2	Reactor 3
Chemical characteristics				
Fat	5.90 a ± 0.40	5.85 a ± 0.46	5.82 a ± 0.40	5.88 a ± 0.39
Non Fats	9.73 a ± 0.16	9.61 a ± 0.03	9.57 a ± 0.03	9.60 a ± 0.04
Protein	5.28 a ± 0.11	5.21 a ± 0.05	5.19 a ± 0.03	5.22 a ± 0.03
Lactose	3.54 a ± 0.06	3.49 a ± 0.03	3.48 a ± 0.03	3.47 a ± 0.03
Dry weight	15.63 a ± 0.52	15.45 a ± 0.47	15.38 a ± 0.39	15.48 a ± 0.39
Water content	83.38 a ± 0.52	84.55 a ± 0.47	84.62 a ± 0.39	84.53 a ± 0.39

<sup>a</sup> The milk samples were same and did not get circulation-system of UV treatment.

**Table 3.** Chemical characteristics of milk goats treated with the circulation system of UV-C 253.7.

Testing	Treatment			
	Control <sup>a</sup>	2 circulation	4 circulation	6 circulation
Chemical characteristics				
Fat	6.74 a ± 0.58	6.59 a ± 0.42	6.53 a ± 0.57	6.44 a ± 0.56
Non Fats	9.77 a ± 0.12	9.67 a ± 0.16	9.57 a ± 0.07	9.47 a ± 0.12
Protein	5.35 a ± 0.03	5.29 b ± 0.05	5.24 c ± 0.02	5.18 d ± 0.03
Lactose	3.50 a ± 0.09	3.47 a ± 0.10	3.42 a ± 0.07	3.40 a ± 0.09
Dry weight	16.51 a ± 0.47	16.26 a ± 0.27	16.10 a ± 0.05	15.91 a ± 0.04
Water content	83.49 a ± 0.47	83.74 a ± 0.27	83.91 a ± 0.50	84.09 a ± 0.44

<sup>a</sup> The milk samples were same and did not get circulation-system of UV treatment.

#### 4.2. Fat

The fat content of goat milk was categorized into three criteria, respectively >4.00%, 3.50-4.00%, 3.25-3.50%; 4.10% and 4.50%. The analysis result of variance showed that between control and treatment in the serial and circulation systems did not show any significant difference with a range of value respectively 5.90 - 5.88% and 6.74 – 6.44% and tended to decrease. This was possible because fat globules were unstable, broken due to the circulation or stuck to the container. The measurement results of fat content both control and treatment still fulfilled the requirements. The fat content was influenced by the viscosity, viscosity increased because there was a process of protein coagulation which caused the broken of casein cell granules that also caused the increased fat content. Some conditions and treatments which influenced the casein stability that influenced significantly on the viscosity of milk were pH, salt balance, heat treatment, enzyme and bacteria.

The decreased fat content occurred because fat was hydrophobic which caused fat fraction to separate from the water and stuck on the surface of milk container. The lower the milk flow rate (contacted with high container) caused the contact between fat fraction and non-fat fraction. When the fat globules were separated at the time milk was flowed, then fat globules dispersed was enveloped by protein, in which the non-polar part of protein was bound to the outside of fat globules, while polar part of protein was bound to water. The lower the milk flow rate was claimed to be the more fat was bound by non-fat fraction.

#### 4.3. Value of non-fat dry materials

The results of analysis of variance on non fats levels between control and treatment in the serial and circulation systems did not show any significant difference with the range values respectively 9.73 - 9.60% and 9.77-9.47% and tended to decrease at a declining rate of 0.13% and 0.30%. This means that

the serial and circulation treatments did not change non-fat compounds. The non-fat dry materials (non fats) in milk were composed of: albumin (casein and protein), lactose, vitamins, enzymes, and gas. Non fats values were still above the required non fats levels.

#### 4.4. Protein

The results of analysis of variance between control and treatment for the serial system were not significantly different with the range value of 5.28 - 5.22% while in the circulation system showed a significant difference with the range of values of 5.35 - 5.18%, and decreased. The value of control and treatment protein levels in both serial and circulation systems was still higher than the required protein content. Protein in milk was a determinant of the quality of milk as a consumption material.

#### 4.5. Lactose

The results of analysis of variance on lactose content of goat milk showed that between control and treatment did not significantly affect the value of lactose levels in both serial and circulation systems with values ranging from 3.54 to 3.47% and 3.50-3.40% with a decrease rate of 0.07% and 0.10% respectively. The value of control and treatment lactose content was lower than required. This was because the level of lactose was very determined by the season, the level of lactation, the increase in the value of fat, protein, non fats and minerals which caused the value of lactose levels was low. Lactose content of goat milk was approximately 0.2-0.5% lower than cow's milk.

#### 4.6. Dry weight

The results of analysis of variance showed that the serial and circulation systems of dry weight in goat milk was not significantly different although it decreased with values of 15.63-15.48% and 16.51-15.91% with decreases respectively 0.15% and 0.60%. The dry weight value of goat milk still met the requirements. The BK value was a combination of the value of fat content and non-fat dry materials. If the value of fat content and non-fat dry materials decreased, the dry weight value also decreased.

#### 4.7. Water content

The results of the analysis of variance showed that the serial and circulation systems of water content in goat milk were not significantly different with the values of 83.88-84.53% and 83.49-84.09% with increase in water content respectively of 0.65% and 0.60%. The value of goat milk content was still below the required value. This was because the value of dry weight of goat milk results in research was far above the required dry weight value.

In general, the physical and chemical properties of goat milk which were given a treatment of UV-C 253.7 nm of serial system with dose/reactor, flow rate and treatment/reactor time were 1.81 J/cm<sup>2</sup>, 4.32 ± 0.71 cc/second and 53.24 seconds, and circulation system with dose/reactor /flow rate and treatment time respectively 1.56 J/cm<sup>2</sup>, 10 cc/second and 23 seconds/circulation did not show any significant difference compared to control and met the requirements.

#### 4.8. Microorganisms inactivation of UV method arranged in serial

Based on the value of the inactivation rate of microorganisms exposed to the UV-C reactor in reactors 1, 2 and 3 respectively were 0.11; 0.25 and 0.51 log cycles or 23.12%; 37.04% and 69.55%. Inactivation of microorganisms from reactors arranged in serial showed an increase in the value of the inactivation rate. The initial inactivation of microorganisms in UV 1 reactor with a dose of 1.81 J/cm<sup>2</sup> caused most microorganisms that were exposed to UV exposure to still be sub-lethal and still able to multiply themselves, if the dose was increased to 5.43 J/cm<sup>2</sup>, the properties of the sub-lethal decreased which caused the inactivation level increased. This was consistent with the opinion that UV reactors arranged in serial caused one bacterial cell to get more than 1 reactor exposure so that the cell was not fully active, the inactivation curve was steeper (Figure 3).

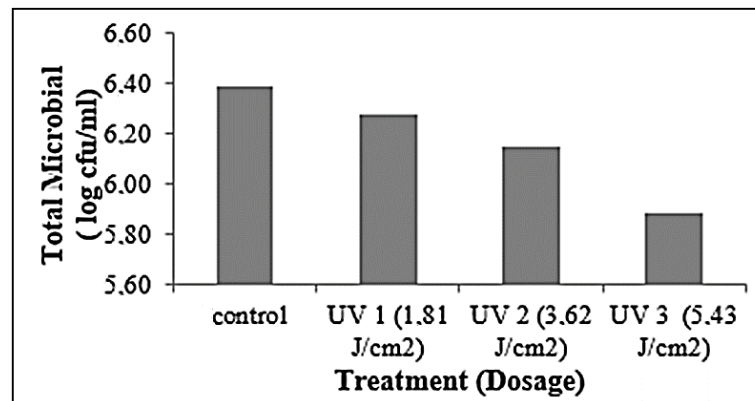

**Figure 3.** Inactivation of microorganisms exposed to the reactor UV-C 253.7 nm arranged in serial.

D value of the 1<sup>st</sup>, 2<sup>nd</sup> and 3<sup>rd</sup> UV reactors are shown in the Table 4.

**Table 4.** Inactivation and D value.

Reactor	Microorganism reduction (%)	inactivation (log cfu/ml)	Inactivation rate (log fu/ml/hour)	D (hour)
UV 1	23.12	0.11	7.75	0.13
UV 2	37.04	0.25	8.31	0.12
UV 3	69.55	0.51	11.48	0.09

D value in the 3<sup>rd</sup> UV reactor was obtained at 0.09 hours which means the time needed to inactivate microorganisms as much as one log cycle took 313.49 seconds.

Inactivation of microorganisms due to UV exposure was categorized into three mechanisms, namely: (a) chemical effects, namely chemical changes in DNA and RNA that caused inactivation of microorganisms due to failure in replication, (b) the effect of heat, which produced heat pressure which was caused by differences in the absorption of UV rays by microorganisms and the surface of the media. This condition caused absorption of water in bacterial cells which resulted in an imbalance of osmotic pressure so that the cytoplasm was damaged which resulted fragile cells and (c) physical effects, the high energy produced caused constant physical changes, where in the cell wall structure became damaged and broken. This mechanism clearly showed that UV rays did not cause genetic changes in the bacterial cell structure, but also caused cell damage and cell rupture.

## 5. Conclusions

The conclusion obtained from the research of UV exposure in the serial and circulation systems of the chemical and microbiological properties of goat milk, as follows: the treatment of UV system exposure to the serial system was not significantly different from the chemical properties, while the circulation system caused a significant difference in protein content, in general, the chemical properties of treated goat milk still met the requirements of Thai Agricultural Standards, the treatment of UV exposure with 3 reactors arranged in serial was the best treatment with inactivation of microorganisms and the doses of reactors 1, 2 and 3 were respectively 0.11; 0.25; 0.51 log cycle and 1.81 J/cm<sup>2</sup>; 3.62 J/cm<sup>2</sup>; 5.43 J/cm<sup>2</sup>, the D value was 313.49 seconds with the speed and treatment time rates of 4.32 ± 0.71 cc/second and 159.72 seconds, respectively.

## 6. References

- [1] Ranadheera C S, Evans C A, Adams M and Baines S K 2016 *Small Ruminant Research* **136** 104-108



- [2] Cosentino C, Paolino R., Musto M and Freschi P 2015 *The Sustainability of Agro-Food and Natural Resource Systems in the Mediterranean Basin* 113-132
- [3] Haile S 2015 *Quality Assessment of Cattle Milk in Adea Berga and Ejerie Districts of West Shoa Zone, Ethiopia* (Ethiopia: Haramaya University)
- [4] Balthazar C et al 2017 *Comprehensive Reviews in Food Science and Food Safety* **16** 247-262.
- [5] Nguyen H T, Ong L, Beaucher E, Madec M N, Kentish S E, Gras S L and Lopez C 2015 *Food Research International* **67** 35-43
- [6] Ombarak R A, Hinenoya A, Awasthi S P, Iguchi A, Shima A, Elbagory A R M and Yamasaki S 2016 *Egypt International Journal of Food Microbiology* **221** 69-76
- [7] Thirumdas R, Sarangapani C and Annapure U S 2015 *Food Biophysics* **10** 1-11
- [8] Chen C, Hu W, He Y, Jiang A and Zhang R 2016 *Postharvest Biology and Technology* **111** 126-131
- [9] Jenny R M, Jasper M N, Simmons III O D, Shatalov M and Ducoste J J 2015 *Water Research* **83** 310-318
- [10] Bhullar M S, Patras A, Kilanzo-Nthenge A, Pokharel B, Yannam S K, Rakariyatham K and Sasges M 2018 *Food Research International* **103** 59-67
- [11] Halliwell B and Gutteridge J M 2015 *Free Radicals in Biology and Medicine* (USA: Oxford University Press)
- [12] Verraes C et al 2015 *International Dairy Journal* **50** 32-44
- [13] Rodrigues B L et al 2016 *Food Control* **60** 596-605
- [14] Iranshahi M, Rezaee R, Parhiz H, Roohbakhsh A and Soltani F 2015 *Life Sciences* **137** 125-132

### Acknowledgments

Our thank goes to Department of Agricultural Engineering, Politeknik Negeri Jember, who has helped support for this research.