

Portable Smart System on Chip for Moisture Detection and Watering Melon Plants

by Nuzula Afianah

Submission date: 16-Aug-2024 09:07AM (UTC+0700)

Submission ID: 2432724779

File name: 2024_-_Draft_Jurnal_IJSMM.pdf (506.54K)

Word count: 2542

Character count: 11587

Portable Smart System on Chip for Moisture Detection and Watering Melon Plants

Nuzula Afianah, Salsabila Liandra Putri, Moh. Dwi Feby Velani, Tegar Dwi Ananta
Mechatronics Engineering Technology, Politeknik Negeri Jember
Jember, East Java, Indonesia
nuzula.afianah@polije.ac.id

Abstract— Nowadays, digital transformation has become a part of everyday life. One important sector is agriculture. Agricultural technology was developed for the needs of greenhouse Polije as a technology factory development unit. One of the challenges for greenhouse farmers is monitoring the soil condition of melon plants, which requires watering according to the plant's soil moisture. Precision agricultural technology has a new look and supports the implementation of smart systems on chips in portable form. The portable smart system on chip is equipped with a processing and controlling unit, namely ESP32 and several supporting sensors. The results of the sensor readings become a benchmark for watering. Sensor data acquisition shows real time reading results with an error on the DHT22 sensor of 3.73%, the DS18B20 sensor of 3.8% and the soil moisture sensor is known to have an average normal condition at a percentage of 45.6%. The three sensors have an average response time of 2.4 seconds.

Index Terms— Portable, smart system, SoC, melon plants.

I. INTRODUCTION

Challenges experienced by farmers in detecting soil moisture visually based on color and visible conditions. Previous conventional methods that only relied on visual observations of soil color, texture and visual condition of the soil surface have proven to be inefficient and inaccurate in determining soil moisture. Variations in soil color are a major obstacle, causing difficulties in identifying soil surface textures which are important for plant growth[1].

The lack of appropriate tools to detect soil moisture, especially those that can measure soil moisture and air temperature, has resulted in less than optimal agricultural results. This condition has a direct impact on the productivity and welfare of farmers, especially for those who grow plants in greenhouses such as melons which really need special attention to soil conditions. Therefore, developing a system on chip device that is able to accurately detect soil fertility is very important. This research aims to create a solution that utilizes the latest technology, such as the ESP32 as the main controller, as well as the soil moisture sensor and DHT22 sensor and the DS18B20 sensor as the main component in detecting the condition of the soil and surrounding space.

The integration of sensors and system on chip (SoC)[2] on the ESP32 becomes the core of the smart system in portable form which will be designed and developed in this research. The portable smart SoC can control watering melon plants based on reading soil moisture data which is a benchmark for

watering. Apart from automatically controlling the smart system, farmers can also water using an application on a mobile computing-based system, in this case using a smartphone with the MIT App Inventor application software.



Fig. 1. The Intended Greenhouse

Melon plants produced by the TeFa Polije greenhouse[3] are the target of system design and implementation for data logger system. The development environment supports testing and validation of the smart SoC at certain times as well as monitoring plants at the desired time using a portable smart system. This also helps the precision agricultural technology that Polije is developing to improve the digital transformation of the agricultural industry.

This research aims to the portable smart system on chip will give farmers better access to knowing the moisture conditions in the soil. They can manage plant watering more efficiently, by setting the time and amount of water needed based on the data provided by the device. This is expected to increase overall agricultural productivity and reduce losses due to inappropriate land management..

II. RESEARCH METHOD

The appearance of the actual conditions for planting melons in the Tefa Greenhouse Polije is shown in Fig. 1. In the picture, a location survey and system requirements are carried out. Generally, the watering process is carried out on a schedule with the operator observing the condition of the plants directly and if he feels it is time to water, the operator or gardener will turn on the watering pump. Uneven watering conditions sometimes require special handling, so gardeners need to water certain areas that have not been watered or in certain cases require extra watering. The extra condition in question is a dry area that requires watering.

A. Planning System

The planning stage is the first step in the process of creating a design of portable smart SoC, because in this planning it will be determined what system will be built so that it can function optimally. Therefore, planning must be done carefully so that the resulting system is truly optimal. There are so many problems that arise that technology is needed to deal with some of the problems that farmers often experience. So far, manual methods have been used to monitor soil moisture for plants in the tefa greenhouse polije. However, if this portable smart system is used as a tool for monitoring soil moisture in plants in the tefa greenhouse polije, it will certainly save farmers time and energy in monitoring soil moisture because it can be accessed via an application on a smartphone.

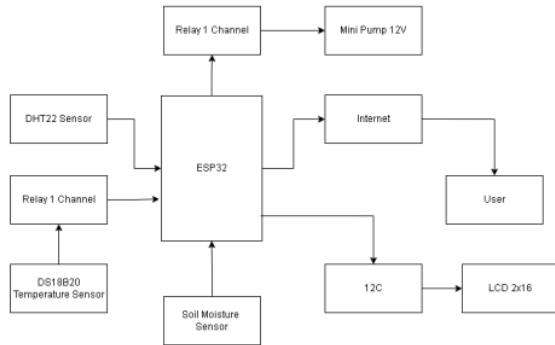

Fig. 2. Block diagram of portable smart SoC

System design as shown in Figure 2 consists of designing components in an integrated on-chip system with sensor input and output. As an input unit, there is a DHT22 sensor that have functions for better air humidity data acquisition[4]. DS18B20 sensor as a water temperature data reader. The DS18S20 sensor can take temperature readings from -55 °C to +125 °C with a resolution of 9 bits to 12 bits. The next input is the soil moisture reading by the soil moisture sensor. The system output is displayed on the LCD on the portable smart SoC and mobile application.

B. Implementation System

System implementation begins with formulating an algorithm on the system flowchart. This flowchart is the basis for translating the steps in the pseudo code program in the Arduino IDE and MIT App Inventor software. Portable smart systems have two types of control systems, namely manual and automatic control as shown in the picture 3. It is necessary to measure the power used for each component to estimate the power requirements required by the system using ohm law and joule law, based on fig 2.

Implementation on hardware system stated by initialization process shown in the picture 3. Initialization sensors, display and actuator. After the system output results are read, the system needs to be calibrated using a valid calibrator. The difference in data read by the system and the calibrator is an error obtained using a formula. Sum of error accumulated and the average of error is calculated.

$$E_r = (X_m - X_a) / X_a \times 100\% \quad (3)$$

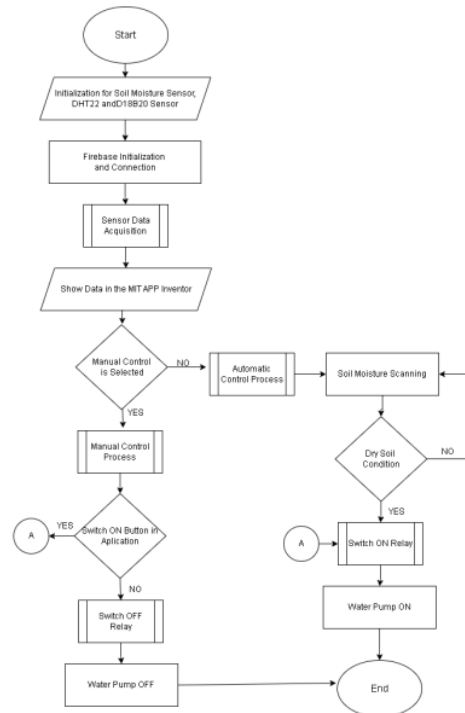

Fig. 3. Flowchart Portable Smart SoC

C. Data Analysis

The analysis stage is carried out to measure the level of efficiency of the portable smart system that has been designed. At this stage, the humidity sensor measurements are entered into several categories with parameters as in table 1. The wet category is included in the classification of high and very high levels of soil moisture index (SMI)[5]. Apart from analyzing the soil moisture sensor measurement data, the DHT22 sensor and D18B20 sensor measurements are then calibrated using a sensor meter.

TABLE I. PARAMETERS OF THE SOIL MOISTURE

Soil Moisture Indicator		
Condition	Sensor Value	Sensor Percentage
Dry	2800-3500	0 – 25%
Quite dry	2500-2800	25 – 35%
Normal	2200-2500	35 – 50%
Wet	1800-2200	50% - 100%

D. Experimental method

In this experiment, the actuator's performance was based on temperature and soil moisture sensor readings which indicated dry soil conditions that required watering. watering is done

based on the reading value and will stop automatically based on the reading value too. The parameter for stopping watering is when the soil condition is indicated to be 65% wet. The performance of the portable smart SoC is discussed from two phases: namely the speed of monitoring response time and the speed of watering response time.

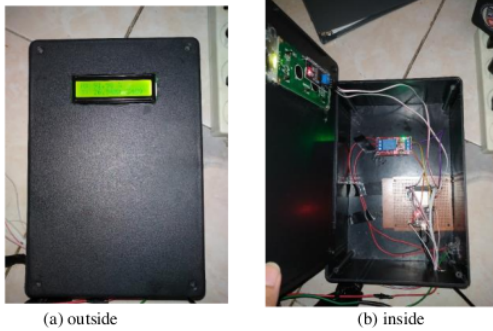

Fig. 4. Appearance of portable smart SoC

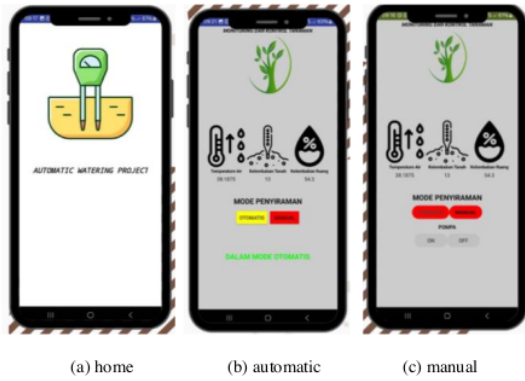

Fig. 5. Mobile application of portable smart SoC



Fig. 6. Experiment environment

The appearance of the portable smart system on chip is shown in the figure 4. The external appearance of the system displays the reading results on the LCD, while the internal appearance contains an electronic circuit of the constituent components in an integrated chip. Watering control can be used in automatic mode as shown in the figure 5 and it can use manual mode using on and off button in the application. System testing was carried out as in the figure 6 using melon plants in the Tefa greenhouse of Polije.

E. Experimental results

The experimental results are shown in Fig. 5 and Fig. 6. It is seen from Fig. 5 that the improved manta robot has high propulsive speed for the propulsive force, compared to the conventional Manta robot. From this result, it is considered that the improved manta robot has low propulsive resistance, compared to the conventional manta robot.

TABLE II. SENSOR DHT22 TESTING RESULT

Time	RH	V	A	W	RHs	Er	Δt
12.10	48.3	3.3	0.001	0.0033	48	6.25%	1s
12.15	48.0	3.3	0.001	0.0033	47.7	6.28%	3s
12.20	46.9	3.3	0.001	0.0033	46.9	0%	2s
12.25	48.1	3.3	0.001	0.0033	47.9	4.17%	4s
12.30	47.7	3.3	0.001	0.0033	47.6	2.10%	1s
12.35	48.5	3.3	0.001	0.0033	48.2	6.22%	2s
12.40	49.3	3.3	0.001	0.0033	49.1	4.07%	3s
12.45	49.3	3.3	0.001	0.0033	49.1	4.07%	2s
12.50	48.8	3.3	0.001	0.0033	48.6	4.11%	3s
12.55	49.1	3.3	0.001	0.0033	49.1	0%	2s

TABLE III. SENSOR SOIL MOISTURE TESTING RESULT

Time	SMI	V	A	W	%	Indicated	Δt
12.10	2867	3.3	0.000702	0.00232	36	normal	2s
12.15	1804	3.3	0.000702	0.00232	56	wet	3s
12.20	2230	3.3	0.000702	0.00232	48	normal	2s
12.25	2345	3.3	0.000702	0.00232	46	normal	3s
12.30	2366	3.3	0.000702	0.00232	46	normal	2s
12.35	2402	3.3	0.000702	0.00232	45	normal	2s
12.40	2436	3.3	0.000702	0.00232	45	normal	3s
12.45	2445	3.3	0.000702	0.00232	45	normal	2s
12.50	2453	3.3	0.000702	0.00232	45	normal	2s
12.55	2467	3.3	0.000702	0.00232	44	normal	3s

TABLE IV. SENSOR DS18B20 TESTING RESULT

Time	T	V	A	W	T_s	Er	Δt
12.10	36.56	3.3	0.000702	0.00232	33.4	9.46%	2s
12.15	31.36	3.3	0.000702	0.00232	32.2	2.55%	3s
12.20	30.56	3.3	0.000702	0.00232	32.3	5.38%	2s
12.25	31.87	3.3	0.000702	0.00232	32.4	1.64%	4s
12.30	32.81	3.3	0.000702	0.00232	32.4	1.26%	1s
12.35	33.56	3.3	0.000702	0.00232	32.5	3.26%	2s
12.40	33.56	3.3	0.000702	0.00232	32.6	3.94%	3s
12.45	33.49	3.3	0.000702	0.00232	32.7	2.42%	2s
12.50	34.03	3.3	0.000702	0.00232	32.8	3.97%	3s

Time	<i>T</i>	<i>V</i>	<i>A</i>	<i>W</i>	<i>T_s</i>	<i>Er</i>	Δt
12.55	34.22	3.3	0.000702	0.00232	32.8	4.12%	2s

TABLE V. WATERING CONTROL TESTING RESULT

Date	Control	Water Pump	Time ON	SMI(%)	<i>V</i>	<i>A</i>	<i>W</i>	Δt
24/05/2024	Auto	ON	10s	89.88%	12	2	24	2s
25/05/2024	Auto	ON	13s	90.50%	12	2	24	3s
26/05/2024	Auto	ON	9s	96.50%	12	2	24	3s
24/05/2024	Manual	ON	8s	85.50%	12	2	24	4s
25/05/2024	Manual	OFF	10s	87.90%	12	2	24	1s
26/05/2024	Manual	ON	11s	88.40%	12	2	24	2s
26/05/2024	Auto	ON	10s	92.67%	12	2	24	3s
27/05/2024	Auto	OFF	12s	85.70%	12	2	24	2s
27/05/2024	Manual	ON	8s	85.65%	12	2	24	3s
27/05/2024	Manual	OFF	14s	93.43%	12	2	24	2s

The research results show that the test used the DHT22 sensor to display air humidity in the greenhouse with an average of 48.4 RH, while the average sensor meter was 48.22 RH with an error of 3.73% and a response time of 2.4 seconds. Meanwhile, the results of research on testing using a soil moisture sensor to display soil moisture showed an average SMI of 2381.5, so it is indicated that it is in normal condition because the average reading percentage is 45.6% and the response time is 2.4 seconds. The results of the DS18B20 sensor show that the water temperature reading results were an average of 33.23°C. The meter sensor reading results at the same time were 32.61°C. so the average error is 3.8% and the

response time is 2.4 seconds. The average watering time is 10.5 seconds, with manual watering the average is 10.2 seconds with direct sensing results, while the average automatic watering is 10.8 seconds with sensor reading results.

III. CONCLUSION

In this paper, the portable smart SoC implementation shows good performance. Apart from being expected to be able to support precision agriculture which is being developed, test results using a portable smart SoC also show satisfactory results. The use of the DHT22 sensor has an error of 3.73%, while the DS18B20 sensor reading on the Tefa Greenhouse Polije is 3.8%. So it can be concluded that the error obtained is <5%. Watering carried out through the smart system has an average watering time of 10.5 seconds and is able to meet the water needs of plants whenever needed.

REFERENCES

- [1] C. Agustina, N. Kusumarini, and M. L. Rayes, "Mapping soil fertility capability classes as a basis for identifying problems and strategies for managing paddy fields", *Journal of Soil and Land Resources* 9, no. 2, pp. 421-429, 2022.
- [2] F. Farimah, Y. Huang, and P. Mishra, "System-on-chip security", Cham, Switzerland: Springer, 2020.
- [3] A. Rizqi, "Fertigation System for Melon Seed Production (Cucumis melo L.) at the Jember State Polytechnic Smart Green House", 2021.
- [4] S. A. Hendra, "Comparison of temperature and humidity measurement accuracy between DHT11 and DHT22 sensors", *Journal infotel* 6, no. 2, pp. 49-56, 2014.
- [5] D. A. Muhammad, and R. Nurtyawan, "Soil Moisture Analysis Map Using The Soil Moisture Index Method (SMI) Based on Landsat 9 Image (Study case: Bandung City, West Java)," FTSP Series: National Seminar and Final Assignment Dissemination, 2023.

Portable Smart System on Chip for Moisture Detection and Watering Melon Plants

ORIGINALITY REPORT

1 %	1 %	%	%
SIMILARITY INDEX	INTERNET SOURCES	PUBLICATIONS	STUDENT PAPERS

PRIMARY SOURCES

1	www.oswa.ch Internet Source	1 %
2	s3.amazonaws.com Internet Source	< 1 %
3	sipora.polije.ac.id Internet Source	< 1 %

Exclude quotes Off Exclude matches Off
Exclude bibliography Off