

Paper Jurnal/Prosiding

by Choirul Huda

Submission date: 08-Nov-2023 10:07AM (UTC+0700)

Submission ID: 2221270037

File name: lizes_an_IoT_Technology_-_Choirul_Huda,_S.Kom.,_M.Kom_POLIJE.pdf (898.63K)

Word count: 4412

Character count: 23623

3 A Smart Greenhouse Production System Utilizes an IoT Technology

Choirul Huda¹, Bety Etikasari², Pramuditha Shinta Dewi Puspitasari³

^{1,2,3} Department of Information Technology, Politeknik Negeri Jember, Indonesia

¹chuda@polije.ac.id ²bety.etikasari@polije.ac.id, ³pramuditha@polije.ac.id

1
Abstract - Food is an essential need for every living creature. Choosing the wrong food leads to serious problems e.g. indigestion, obesity, diabetes mellitus, stroke, including heart disease that causes death. To prevent those diseases from harming the body, people should be concerned about food consumption, for example by consuming organic food. Organic food is obtained by cultivating plants in a greenhouse to increase production, minimize risk, prevent disease, and be safer against environmental risk. However, some obstacles faced by farmers such as disease or pests, water supply, temperature, and so on. Based on some previous research, the problem is dominated by soil moisture since the farmer has to water all plants manually. It has affected crop yields directly. If this phenomenon is not handled properly, farmers are threatened with losses so organic farming becomes a catastrophe. Therefore, in this research, an IoT technology is proposed to increase soil moisture in real time. The proposed system is also equipped with a Web-based information system to expose the cultivation phase, and market crops, as well as a tool for buyers as interaction media through the feedback provided. In the end, the proposed system is adequate to increase the productivity of vegetable cultivation grown in a greenhouse. Based on some experiments that have been done, the proposed method is capable to work optimally and effectively meet user needs by 95.55%.

Keywords: Greenhouse, production, vegetables, IoT, soil moisture.

3 I. INTRODUCTION

3
Food is an essential need for every living creature, especially humans. The body needs food with balanced nutritional values such as vitamins, minerals, carbohydrates, protein, fiber, and water. Those ingredients are found in various types of food, notably fruits and vegetables. Choosing the wrong food like convenience or fast food leads to serious problems such as indigestion, obesity, diabetes mellitus, stroke, including heart disease that threatens life and even causes death [1]-[2].

The solution to this phenomenon is taking organic foods consumption. Some research that have been proven that organic food contains higher of phenolic and omega-3 fatty acids than conventional products [3]-[4]. Omega-3 is efficient to reduce the risk of cardiovascular disease, dementia, and boosting heart and mental health. Meanwhile, phenolic is an antiseptic to treat infections in the body. There are many other benefits that are contained and prove how important organic food is. Those studies convince that healthy food has a big role in the health of the body.

Organic food is associated with freshness and naturalness, rich in healthy components, and also lowers or even absent of pesticides. This product must be consumed daily, have a significant impact on health, and have limited or no side effects on fitness [5]-[6]. Therefore, organic food must be easily obtained without requiring significant effort. There is some approach to bringing organic food such as purchasing from the market or through an online shop, or even farming.

Purchasing is indeed the easiest choice, but the quality of the ingredients is questionable, such as the level of freshness, and nutritional content, or even being wary of contamination with pesticides. Farming is one of the ideal solutions, but this lack of implementation especially in an urban environment with a limited field [7]. To take those phenomena down, a greenhouse is the proper way to produce fresh, healthy, hygienic, and guaranteed quality organic vegetables and fruits [8].

Dilemmas arise at the time of implementing greenhouse production such as pests or diseases, water supply, temperature, and so on. Nonetheless, the most problem faced by all farmers is encountered is the level of soil fertility [9]-[11]. In addition, compared to conventional farming, low yields are other challenges that Organic Farming farmers have to face [12]-[13]. In the end, the question emerge, could Organic Farming produce enough food for the world? [14]

For those reasons, in this study, a comprehensive system to organize the management of Organic Farming, especially vegetables proposed. The proposed method

has two sections, firstly utilizes IoT technology to regulate soil fertility levels during the planting process. Secondly is the development of a web-based information system that is used to increase the post-harvest productivity of farmers. An IoT system utilizes microcontroller devices and sensors to maintain soil moisture. By adding a particular electronic driver, the system collaborates with other devices in order to run automatically. It aims to support farmers observe cultivate growth to be more healthy and fertile. Meanwhile, the information system is web-based displays organic crop cultivation and harvesting activities, as well as yields produced from greenhouse production such as fresh and processed vegetables. The proposed system will be discussed further in the next chapter.

II. METHOD

The study is organized into 3 step which are research environment, system design, and system workflow. Each section will be further discussed below.

A. Research Environment

The Proposed System is implemented in a production greenhouse with dimensions of 4x6m² based on limited environmental conditions. The land has 3 plots is planted with various vegetables that can be consumed daily, or even as a major need. The cultivated vegetables include Kale, Spring Onions, Mint Leaves, Kai-lan, Bok Choi, Mustard Greens, Beets, and Celery. It is crucial to fully consider the environment where the system is implemented in order to utilize the IOT devices as much as possible.

B. System Design

As a presence, IoT had a huge impact since the capability to be applied in various fields such as manufacturing, traffic and education, and even in the health field [15]–[19]. Based on the fruitfulness of previous research, in this study, an IOT Technology is implemented for a number of advantages such as convenient implementation, collaboration with other devices, and affordable prices.

IoT stands for Internet of Things describes how various machines interact with their surroundings and vice versa. The interaction starts from simple to complex things such as monitoring devices to sensing devices. The machines are microprocessors, microcontrollers, sensor devices, monitoring devices, and other electronic devices (Fig. 1 and 2). IoT also involves the connectivity

of each things and ensures that the connection is constantly maintained [20].

In this research, the IoT technology will be used in agriculture field to organize soil moisture levels in vegetable crops. Plants will be produced in a greenhouse with a limited area. The system is designed to irrigate soil automatically in real-time based on the plant needs appropriately.

Fig. 1 shows a schematic diagram of the IoT devices in greenhouse production of the proposed method. The IoT devices consist of Arduino Uno R3, Soil Moisture Sensor, Liquid Crystal Display (LCD) 16x2 with I2C Converter, 12V Water Pump, Relay DC 12V, Resistor, Transistor BC548, and AC to DC Converter connected to the power supply. All those things are the minimum specifications of IoT Concepts implemented in agriculture field[21], [22].

Arduino Uno R3 was picked since it has more in/out pins than the others in order to be more efficient for further development. Mostly, Soil Moisture sensors have 2 types, which are Resistive and Capacitive. Resistive works by sending a current through both probes to measure the volumetric water of the resistance value. This sensor is prone to corrosion since it is directly installed to the ground. Meanwhile, Capacitive measures soil moisture by capacitive sensing, anti-corrosion, and has a longer service life than Resistive. Therefore, this research recommended utilizing a capacitive soil moisture sensor. LCD 1602 I2C is employed as an interface for farmers to recognize real-time moisture levels. The data is displayed in percentage of soil conditions which are consist of poor, medium, or moisture. The 12V Water Pump was chosen since the capability to distribute more water than the lower type. It is efficient for farmers to irrigate crops on several fields simultaneously.

Fig. 2 illustrates a mockup of the Web-based Information System of current research. The system has 4 elements consisting of the Home page, Product page, Activities page, and About Us page. The Home page displays general information regarding the product's yield such as various types of vegetables, contact persons, and even the location of the greenhouse. This page also features customer reviews of vegetables in response to their purchase. The Product page provides various kinds of products, such as fresh and processed vegetables. The Activities Page shows occupation during the process of planting to harvesting. Meanwhile, the About Us Page contains a brief description of the establishment of a greenhouse towards the importance of organic vegetables to support a healthy life.

C. System Workflow

There are 4 phases of the greenhouse production

system consists of Identifying, Moisturizing, Validating, and Harvesting as shown in Fig.3.

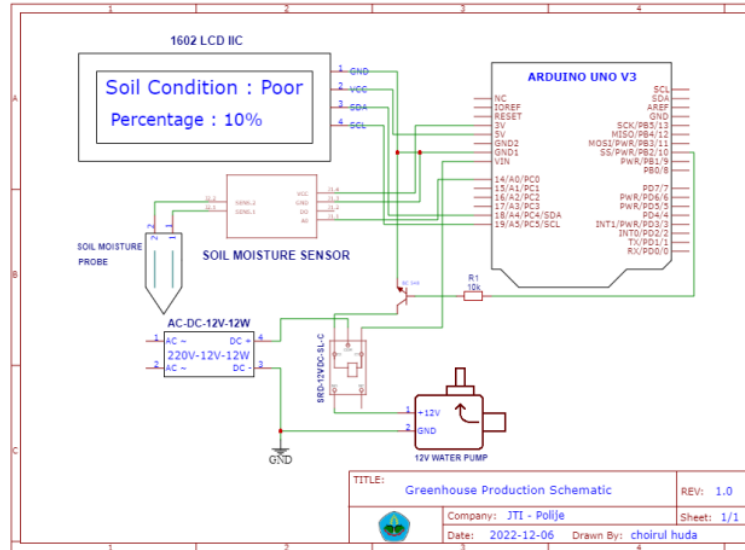

Fig. 1 Schematic diagram of the IoT devices

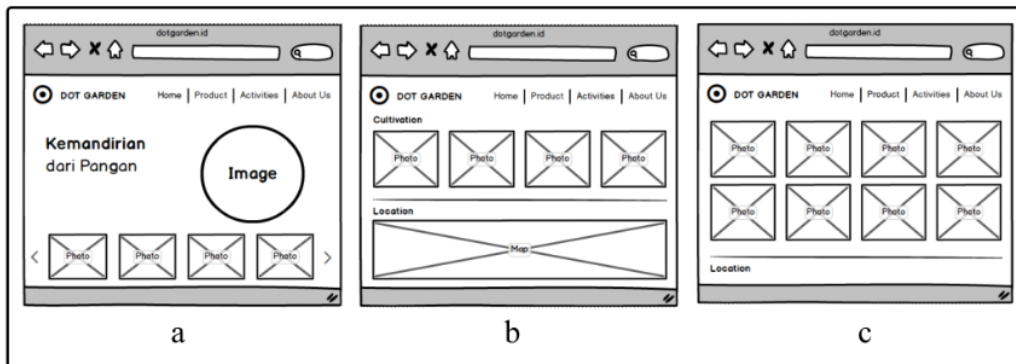

Fig. 2 Mockup of web-based information system: (a) home page; (b) activity page; (c) product page

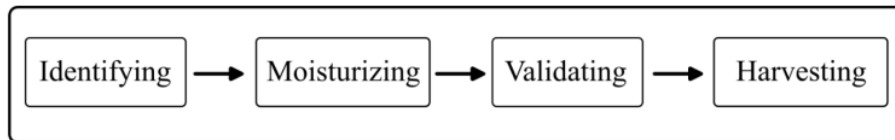

Fig. 3 Workflow of the greenhouse production system

One of the things in the IoT concept is a sensor such as a temperature, humidity, vibration, or even light sensor. Those kinds of devices must interact with the surroundings to seize or measure phenomena in real conditions. In some previous studies, the sensor has a significant role to collect data in many ways and then deliver actions based on the knowledge that has been captured. According to that, Identifying was chosen as the initial phase of the current research. After that, the proposed system has to provide a kind of action as a response to the surrounding in this case Moisturizing the soil of greenhouse production. All actions need to be verified to ensure that the proposed system solves a problem within the study. That's why Validating is selected as the third step.

Lastly, in earlier studies, some researches end with an action as an answer by the system to the environment such as adjusting the valve or turning on the water pump [21]–[23]. However, in this study, the proposed system provides a further response. Not only reply with watering plants but also consider the distribution of a post-harvest product. Therefore, Harvesting was elected as an alternative way to commerce greenhouse products to gain post-harvest profit for farmers.

In the first phase, the system will identify moisture using a Soil Moisture Sensor. This process initiates as the sensor sends data to Arduino Uno. Arduino will convert the value in order to easily measure using (1).

$$x = 100 - \left(\left(\frac{\text{analogRead}(\alpha)}{1023} \right) * 100 \right) \quad (1)$$

α denotes the pin of the Arduino that connected with the Soil Moisture Sensor. *analogRead* states the input reading from the Soil Moisture Sensor connected to pin A0 on Arduino. All devices connected to the pin preceded by A must be read as analog. The output value comes from 0 to 1023. If converted to a voltage rate, then 0 indicates 0V while 1023 states as 5V. Therefore, the analog input divide with 1023. Afterward, the division result (x) will be multiplied by 100 to be easily monitored by percentage values and calculated in logic algorithm as well.

Secondly, the system irrigates the greenhouse fields for a certain time. This stage occurs in the moisturizing phase. The duration of watering depends on the data obtained by the sensor in real-time. If the IoT system indicates the soil is moist, then the irrigation process will discontinue. Conversely, if the land is consistently dry, the system will re-irrigate the ground until reaches more than 70% of soil moisture.

The next stage is to ensure that the plants have received appropriate humidity during the irrigation. This

process occurs in the Validating phase and involves farmers in order to gain vegetables with optimal maturity. Farmers will monitor the plants which will be collected in particular containers in case they mature. After that, the crops will be in the packaging process in the Harvesting phase. At the Validating stage, the difference between ripe and raw vegetables among 1-2 weeks.

Finally, the Harvesting phase consists of selecting, packaging, and uploading vegetables to the web-based information system. Uploading data includes names, types, prices, and photos along with a brief description of the vegetables. Farmers capable to display the cultivation phase during the planting process to convince buyers about the quality of yields. If needed, farmers could market vegetables on the e-commerce site. However, this idea is not recommended since there are opportunities for farmers to sell non-organic vegetables.

III. RESULT AND DISCUSSION

At this stage will discuss the implementation, testing, and analysis of the proposed system. It aims to measure the functionality of the system when assembled in several cases and experiments.

A. Implementation

Fig. 4 shows implementation of the IoT device inside greenhouse production. In Fig. 4(a) the IoT packaged with special box to prevent direct contact with unknown objects such as insects, dusts, branch or even water. The system implements in Berkah Farm Greenhouse Production located in the Kaliurang Area, Jember Regency. The greenhouse produces organic vegetables such as Kale, Spring Onions, Mint Leaves, Kai-lan, Bok Choi, Mustard Greens, Beets, and Celery that planted in 3-4 plots. Each of plot has dimension of 1x6m² and fitted several dripper emitter connected to a water pump via a hose of a certain length.

According to the system workflow, the proposed system consists of 4 processes: Identifying, Moisturizing, and Validating. In the identifying phase, the IoT is installed close to the land within 1 meter and covered with a special box. It is intended that the sensor capable to work optimally by reducing resistance caused by a long cable. The drippers are spread along the land within 1 meter of one another. The moisture sensor is installed between the two adjacent drippers. Figure 4(b) shows the installation of drippers and soil sensors on greenhouse land. This installation is aimed to recognize moisture directly and transmit a signal to the Arduino immediately.

The moisturizing stage is a step for irrigating greenhouse land using a water pump for such a period of time. This process involves 12 V Water Pumps, Relays, and Arduino, as well as hoses and drippers to water the land. The soil will be analyzed by the sensor if it is recognized as dry conditions, then Arduino will pass on the water continuously until the soil level reach 70% of wetness. Figure 4(c) shows the water reservoir and IoT box along with the water pump in the greenhouse area. In certain condition, water can be added with organic liquid fertilizer to increase soil fertility.

The validating stage discusses the analysis of soil moisture levels. If the sensor recognizes that the soil has a wetness level above 70%, the system will halt the irrigation process. Conversely, if the system recognizes that it is still below 70%, then the watering process will

proceed. During the analysis activity, the soil moisture level is displayed in real-time via a 16x2 LCD that is attached to the IOT Box lid.

Last but not least is the Harvesting phase which covers by Web-based Information System shown by Fig. 5. The website is capable to display all information during the planting process including maintenance, displacement to the planting medium, and harvesting. It can be seen in Fig.5(a). In addition, the system is adequate to show fresh and processed products, location, a brief history of the company, and even customer testimony. Furthermore, the system developed to fit with various types of user devices shown by Fig.5(b) and (c). It is necessary in order to work responsively and adaptively.

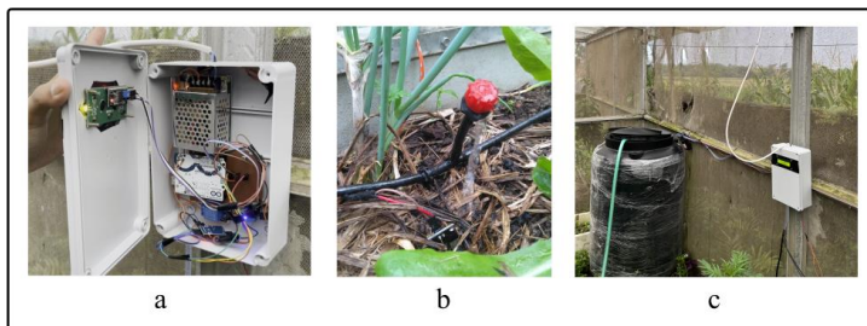

Fig. 4 The implementation of IoT devices inside greenhouse production: (a) the IoT box; (b) soil moisture sensor placement; (c) water reservoir and pump placement

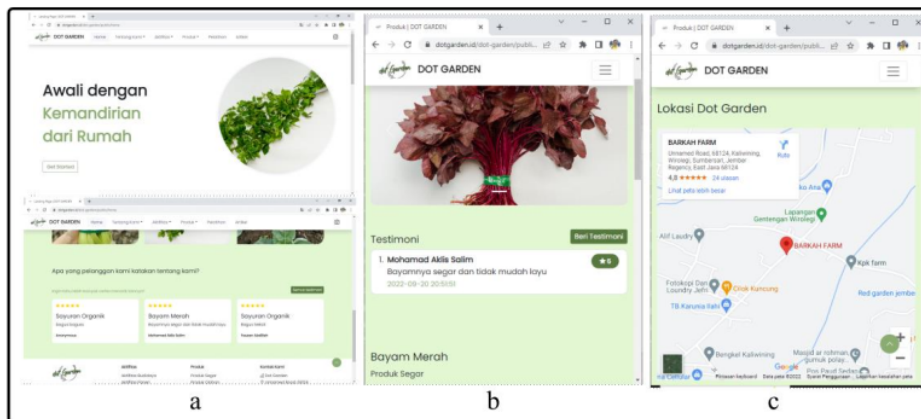

Fig. 5 The web-based information system: (a) home page; (b) customer testimony page; (c) location of the greenhouse production

B. Testing and Analysis

The system was tested utilize Blackbox Testing Method. It was necessary to ensure the system works properly. Blackbox Testing is one of testing method to measure system functionality based on suitability in completing task of requirements. The proposed system is tested in 3-4 days based on the previous research [21].

Table I shows the functional requirements of the proposed system along with the test results. Based on some experiments that have been done the system works effectively and optimally.

Moreover, the web-based also tested employs User Acceptance Test (UAT) to verify whether the proposed system is proven to fulfill customer needs.

Table II illustrates questions of Likert Scale that consist of 5 answer which are Strongly Agree, Agree,

Neutral, Disagree, and Strongly Disagree. Each answer has own point, start with Strongly Agree has 5, Agree has 4, Neutral has 3, Disagree has 2, and the last Strongly Disagree has 1 point respectively.

The UAT distributed to customers who have purchased greenhouse products and interact directly during the cultivation process. The result obtained is 43 out of 45 points. Furthermore, the percentage points are calculated using (2). The a denotes obtained point of the UAT, whereas b is total point of the questionnaire. The results show that the accuracy of the proposed system is 95.55%. It is proves that the proposed method is adequate to meet people's needs regarding the access to organic vegetables effectively.

$$y = \frac{a}{b} * 100\% \quad (2)$$

TABLE I
FUNCTIONAL REQUIREMENTS OF PROPOSED SYSTEM

No.	System Requirements	Date of Testing	Status
1	System capable to capture soil moisture	17-20 September 2022	Valid
2	System capable to expose soil condition in real-time	17-20 September 2022	Valid
3	System capable to irrigate vegetables properly	17-20 September 2022	Valid
4	System capable to display vegetables name, price and description in a website clearly	17-20 September 2022	Valid
5	System capable to show users feedback	17-20 September 2022	Valid

TABLE II
LIST OF QUESTIONS IN LIKERT SCALE OF USER ACCEPTANCE TEST

No.	Questions
1	The website shows the home page attractively.
2	The website shows all products of greenhouse in an interesting way.
3	The website displays a brief history of company clearly.
4	The website displays detail activities of cultivation phase.
5	The website lists greenhouse production contact information clearly.
6	The website allows users to write reviews easily.
7	The website put social media link that is interesting to follow.
8	The website publishes articles related to vegetable cultivation regularly.
9	The website is user friendly interface over all.

IV. CONCLUSION

Drip irrigation system utilizing the IoT technology and website development to market crops are strongly influential in the fruitfulness of cultivating plants especially vegetables which are become essential needs. It is because the proposed system capable to irrigate lands automatically and effectively through some experiment that have been carry out. All the things have important role particularly soil moisture sensor in recognizing process within the ground in real-time. Farmer also capable to monitor land condition through LCD attached to the box that enclose the IoT device. It is used to ensure whether the system works effectively according to the actual soil moisture level. The proposed system does not employ a complex method such as Fuzzy Inference System, Machine Learning and many more due to delays during the analysis of moisture level such as in previous research. Soil Moisture Sensor is the sensing device that implement in this research since soil fertility is main focus in this research. Based on some experiment that have been done, the proposed capable to

work effectively. It can be seen from some requirements that have been completed and User Acceptance Test (UAT) which reached 95.55%. Meanwhile, crops are widely marketed through the website that developed particularly. Buyers could observe the quality of vegetables online since it published start from planting to harvest phase. It was inattention in some previous studies which only discussed the cultivation process. In fact, even though the yields are satisfactory and superior if they are not trade properly then crops will be spoil quickly and of course harm farmers in following day.

ACKNOWLEDGEMENT

The research was achieved in collaboration with Berkah-Farm located in the Kaliurang Environment, Jember District - East Java. Authors also thank to all participant who involved during the research.

REFERENCES

- [1] E. Smith, P. Scarborough, M. Rayner, and A. D. M. Briggs, "Should we tax unhealthy food and drink?," in *Proceedings of the Nutrition Society*, Aug. 2018, vol. 77, pp. 314–320. doi: 10.1017/S0029665117004165.
- [2] P. Jia, M. Luo, Y. Li, J.-S. Zheng, Q. Xiao, and J. Luo, "Fast-food restaurant, unhealthy eating, and childhood obesity: A systematic review and meta-analysis," *Obesity Reviews*, vol. 22, no. S1, p. e12944, 2021, doi: <https://doi.org/10.1111/obr.12944>.
- [3] A. Mie, H. R. Andersen, S. Gunnarsson, J. Kahl, E. Kesse-Guyot, E. Rembialkowska, G. Quaglio, and P. Grandjean, "Human health implications of organic food and organic agriculture: A comprehensive review," *Environ Health*, vol. 16, no. 1, Oct. 2017, doi: 10.1186/s12940-017-0315-4.
- [4] S. Hurtado-Barroso, A. Tresserra-Rimbau, A. Vallverdú-Queralt, and R. M. Lamuela-Raventós, "Organic food and the impact on human health," *Critical Reviews in Food Science and Nutrition*, vol. 59, no. 4, Taylor and Francis Inc., pp. 704–714, Feb. 21, 2019. doi: 10.1080/10408398.2017.1394815.
- [5] J. Baudry, S. Péneau, B. Allès, M. Touvier, S. Hercberg, P. Galan, M. J. Amiot, D. Lairon, C. Méjean, and E. Kesse-Guyot, "Food choice motives when purchasing in organic and conventional consumer clusters: Focus on sustainable concerns (the nutrinet-santé cohort study)," *Nutrients*, vol. 9, no. 2, Feb. 2017, doi: 10.3390/nu9020088.
- [6] M. E. Popa, A. C. Mitelut, E. E. Popa, A. Stan, and V. I. Popa, "Organic foods contribution to nutritional quality and value," *Trends in Food Science and Technology*, vol. 84, Elsevier Ltd, pp. 15–18, Feb. 01, 2019. doi: 10.1016/j.tifs.2018.01.003.
- [7] A. M. Beacham, L. H. Vickers, and J. M. Monaghan, "Vertical farming: a summary of approaches to growing skywards," *J Hort Sci Biotechnol*, vol. 94, no. 3, pp. 277–283, 2019, doi: 10.1080/14620316.2019.1574214.
- [8] E. Nicholls, A. Ely, L. Birkin, P. Basu, and D. Goulson, "The contribution of small-scale food production in urban areas to the sustainable development goals: a review and case study," *Sustain Sci*, vol. 15, no. 6, pp. 1585–1599, 2020, doi: 10.1007/s11625-020-00792-z.
- [9] K. Möller, "Soil fertility status and nutrient input–output flows of specialised organic cropping systems: a review," *Nutrient Cycling in Agroecosystems*, vol. 112, no. 2, Springer Netherlands, pp. 147–164, Nov. 01, 2018. doi: 10.1007/s10705-018-9946-2.
- [10] I. Tsvetkov, A. Atanassov, M. Vlahova, L. Carlier, N. Christov, F. Lefort, K. Rusanov, I. Badjakov, I. Dincheva, M. Tchamitchian, G. Rakleova, L. Georgieva, L. Tamm, A. Iantcheva, J. Herforth-Rahmé, E. Paplomatas, and I. Atanassov, "Plant organic farming research – current status and opportunities for future development," *Biotechnology & Biotechnological Equipment*, vol. 32, no. 2, pp. 241–260, Mar. 2018, doi: 10.1080/13102818.2018.1427509.
- [11] P. Barnwal, S. Devika, S. Singh, T. Behera, A. Chourasia, B. Pramanick, V. S. Meena, and Rakshit, "Chapter 3 - Soil fertility management in organic farming," in *Advances in Organic Farming*, V. S. Meena, S. K. Meena, A. Rakshit, J. Stanley, and C. Srinivasarao, Eds. Woodhead Publishing, 2021, pp. 39–46. doi: <https://doi.org/10.1016/B978-0-12-822358-1.00016-X>.
- [12] S. Knapp and M. G. A. van der Heijden, "A global meta-analysis of yield stability in organic and conservation agriculture," *Nat Commun*, vol. 9, no. 1, p. 3632, 2018, doi: 10.1038/s41467-018-05956-1.
- [13] Z. Jouzi, H. Azadi, F. Taheri, K. Zarafshani, K. Gebrehiwot, S. van Passel, and P. Lebailly, "Organic Farming and Small-Scale Farmers: Main Opportunities and Challenges," *Ecological Economics*, vol. 132, Elsevier B.V., pp. 144–154, Feb. 01, 2017. doi: 10.1016/j.ecolecon.2016.10.016.
- [14] The European Commission, "The crop yield gap between organic and conventional agriculture," *Assess*, Nov. 2018.
- [15] C. Yang, W. Shen, and X. Wang, "The Internet of Things in Manufacturing: Key Issues and Potential Applications," *IEEE Syst Man Cybern Mag*, vol. 4, no. 4, pp. 6–15, 2018, doi: 10.1109/MSMC.2017.2702391.
- [16] R. Y. Zhong, X. Xu, E. Klotz, and S. T. Newman, "Intelligent Manufacturing in the Context of Industry 4.0: A Review," *Engineering*, vol. 3, no. 5, pp. 616–630, 2017, doi: <https://doi.org/10.1016/J.ENG.2017.05.015>.
- [17] F. Sadoughi, A. Behmanesh, and N. Sayfour, "Internet of things in medicine: A systematic mapping study," *J*

- Biomed Inform.*, vol. 103, p. 103383, 2020, doi: <https://doi.org/10.1016/j.jbi.2020.103383>.
- [18] A. Frank, Y. S. K. al Aamri, and A. Zayegh, "IoT based Smart Traffic density Control using Image Processing," *2019 4th MEC International Conference on Big Data and Smart City (ICBDSC)*, 2019, pp. 1–4. doi: 10.1109/ICBDSC.2019.8645568.
- [19] D. D. Ramlowat and B. K. Pattanayak, "Exploring the Internet of Things (IoT) in Education: A Review," in *Information Systems Design and Intelligent Applications*, 2019, pp. 245–255.
- [20] S. Greengard, *The Internet of Things, Revised and Updated Edition*, vol. 59. Cambridge: The MIT Press, 2021.
- [21] S. Wahjuni, Wulandari, and M. Kholili, "Development of Fuzzy-Based Smart Drip Irrigation System for Chili Cultivation," vol. 10, no. 1, pp. 115–125, 2022, doi: 10.30595/juita.v10i1.12998.
- [22] K. C. Brata, G. W. Ifan A., and A. H. Brata, "Pembangunan Aplikasi Manajemen Penyiraman Rumput Taman Playground Berbasis Internet of Things," *Jurnal Teknologi Informasi dan Ilmu Komputer*, vol. 8, no. 2, p. 373, Mar. 2021, doi: 10.25126/jtiik.2021824399.

Paper Jurnal/Prosiding

ORIGINALITY REPORT

21 %
SIMILARITY INDEX

20 %
INTERNET SOURCES

14 %
PUBLICATIONS

9 %
STUDENT PAPERS

PRIMARY SOURCES

1 doaj.org Internet Source **5** %

2 repository.itelkom-pwt.ac.id Internet Source **2** %

3 www.scilit.net Internet Source **1** %

4 ebin.pub Internet Source **1** %

5 www.teamsociety.org Internet Source **1** %

6 Shu-Yen Hsu, Chiao-Chen Chang, Tyrone T. Lin. "Safety, sustainability, and consumers' perceived value in affecting purchase intentions toward organic food", 2017 IEEE International Conference on Industrial Engineering and Engineering Management (IEEM), 2017
Publication **1** %

7 www.atlantis-press.com Internet Source **1** %

8

modern-journals.com

Internet Source

1 %

9

Bright Bediako-Kyeremeh, Dickson Keddy Wornyo, Maheesha Dashantha Silva, Henrietta Adjei Pokuaa et al. "A comparative literature review on extensive research on dynamic time warping and its variants for crop forecasting and vegetation using environmental parameters", Institute of Electrical and Electronics Engineers (IEEE), 2023

Publication

1 %

10

uknowledge.uky.edu

Internet Source

1 %

11

pen.ius.edu.ba

Internet Source

1 %

12

gezondeleefomgeving.nl

Internet Source

1 %

13

Nikola Diemer, Philipp Staudacher, Aggrey Atuhaire, Samuel Fuhrmann, Jennifer Inauen. "Smallholder farmers' information behavior differs for organic versus conventional pest management strategies: A qualitative study in Uganda", Journal of Cleaner Production, 2020

Publication

1 %

14

eprints.whiterose.ac.uk

Internet Source

1 %

15 ap-st01.ext.exlibrisgroup.com 1 %
Internet Source

16 Submitted to University of Melbourne 1 %
Student Paper

17 cgspace.cgiar.org 1 %
Internet Source

18 www.journal2.uad.ac.id 1 %
Internet Source

19 www.frontiersin.org 1 %
Internet Source

Exclude quotes Off

Exclude matches < 1%

Exclude bibliography Off