

PAPER • OPEN ACCESS

Design and testing of vertical tubular baffle heat exchanger as an internal reboiler in the distillation device

To cite this article: Y Susmiati *et al* 2019 *IOP Conf. Ser.: Earth Environ. Sci.* **355** 012001

View the [article online](#) for updates and enhancements.

You may also like

- [Numerical simulation of tubes-in-tube heat exchanger in a mixed refrigerant Joule–Thomson cryocooler](#)
R M Damle, P M Ardhapurkar and M D Atrey
- [Study the flow direction and number of tubes in cross-flow heat exchanger to improve the heat transfer coefficient.](#)
Shatha Ali Merdan and Zena khalefa Kadhim
- [Experimental analysis of heat transfer coefficients in phosphoric acid concentration process](#)
Rania Jradi, Ali Fguiri, Christophe Marvillet et al.



244th Electrochemical Society Meeting

October 8 – 12, 2023 • Gothenburg, Sweden

50 symposia in electrochemistry & solid state science

▶ Deadline Extended!
Last chance to submit!

New deadline:
April 21
submit your abstract!

Design and testing of vertical tubular baffle heat exchanger as an internal reboiler in the distillation device

Y Susmiati^{1,2}, B Purwantana³, N Bintoro³ and S Rahayoe³

¹Doctoral student of Agricultural Engineering, Faculty of Agricultural Technology, Universitas Gadjah Mada,

²Lecturer at the Department of Renewable Energy Engineering, Politeknik Negeri Jember

³Lecturer at the Department of Agricultural and Biosystem Engineering, Faculty of Agricultural Technology, Universitas Gadjah Mada.

Email: yuanasusmiati@gmail.com

Abstract. Reboiler in the distillation device is a heat exchanger to heat or boil liquid material in the distillation column. In this research vertical tubular baffle heat exchanger was designed and used as an internal reboiler in the distillation device. The aim of the study was to observe the temperature distribution during the liquid heating process in the vertical tubular baffle heat exchanger with different dimensions. The study was conducted by designing heat exchangers (HE) with different dimensions in height, diameter, and surface area (number) of tubes. Times and fuels needed to heat the liquid to a temperature of 78 °C were calculated. Based on observations it was found that the different geometry of the vertical tubular baffle heat exchanger gives different performance. Height, diameter, and the number of tubes (surface area) affect the value of the overall heat transfer coefficient, times and fuels needed for heating liquids at a temperature of 78 °C. In the same surface area but different in height and diameter of the heat exchanger, give a different result in overall heat transfer coefficient (U). HE with the number of tubes 3 and 7 obtained a higher value of U with a tube height of 4 cm and a diameter of 4 cm, compared with the value of U in HE with a tube 8 cm in high and 2 cm in diameter, but the opposite occurs in HE with a number of tubes 5.

1. Introduction

In the bioethanol distillation device, there are three main components, namely reboiler, distillation column, and condenser. Reboiler is a heat exchanger that serves to vaporize a liquid that falls into the lower column due to the influence of gravity. The function of the reboiler is to reboil and evaporate part of the liquid being processed. Heating media used is steam or heat that is processed itself [1]. The reboiler is used to produce steam supplied to the bottom tray of the distillation column.

Reboiler type selection depends on the factors of material flow characteristics, operating pressure, and equipment layout. The choice of reboiler design also means determining the method of fluid circulation (thermosiphon, forced, or not), also the type of heat exchanger (vertical, horizontal, boiler or internal). Before making the distillation column, the type of reboiler to be used must be determined first because it varies substantially for different type reboilers [2].



The type and geometry of the reboiler greatly determine the efficiency of the heating process of the distilled solution/material because it is related to the heat transfer mechanism in the reboiler. A simple form with good heat transfer, and easy to apply can make the distillation process more efficient. The heat transfer mechanism in the reboiler consists of convection and conduction heat transfer. Convection occurs in fluid (heat vapor and liquid material), and conduction occurs inside the heat exchanger itself. The process of heat transfer is significantly controlled by values of the coefficient of surface heat transfer [3]. Thus a study of the type of reboiler and the heat transfer mechanism is needed.

For small scale industrial bioethanol distillation processes, the reboiler used is usually an internal reboiler type. Internal reboilers also known as stab in reboilers or stab in bundles, are reboiler exchanger bundles, which inserted directly into the tower shell below the bottom tray [4]. There are several types of internal reboilers that have developed at this time including the calandria type [5], the helical tube type [6] and the stub in type [7]. In this research, an internal reboiler with a vertical tubular baffle (VTB) type was developed and the performance testing was carried out.

2. Methodology

The research was carried out with two stages, there are designed and manufactured of a vertical tubular baffle heat exchanger in the form of a prototype, and tested the heat exchanger with the water heating process. The tools used in the study include workshop tools for making internal reboilers such as scissors, hammers, welds, and others, as well as laboratory equipment for trials which include stopwatches, thermocouples (digital thermometers) 4 points, measuring cups, pycnometers, analytical scales, stoves, and others. The materials used in this study are stainless steel plate, water, low-grade bioethanol, soluble aluminium, aluminium foil, and LPG gas.

The internal reboiler prototype is made of stainless steel plate with a thickness of 0.5 mm. In the prototype, the boiler and reboiler become one but divided into two parts with the installation of the vertical tubular baffle. Illustration of the tools made as shown in Figure 1, below.

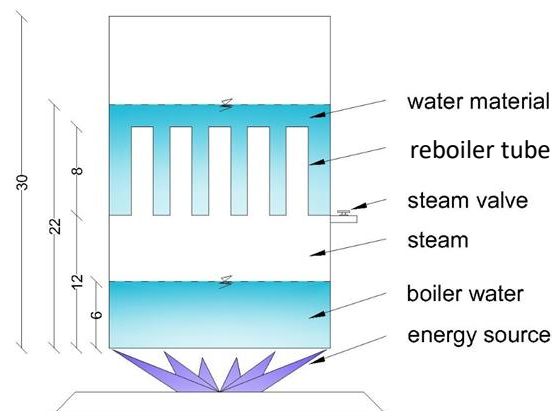

Figure 1. Prototype of internal reboiler vertical tubular baffle

The reboiler tube is made with different sizes of diameter and height, and different number of tubes. Cause of these differences, the heat transfer surface will be different, so give different performance results. There are several dimensions of the reboiler tube tested, namely 8 cm high with a tube diameter of 2 cm and a height of 4 cm with a tube diameter of 4 cm. In each tube size, there are 3 numbers of tubes in each baffle, 3, 5 and 7 tubes. The following picture shows one example of a tube that is arranged in baffles, as many as 7 tubes.

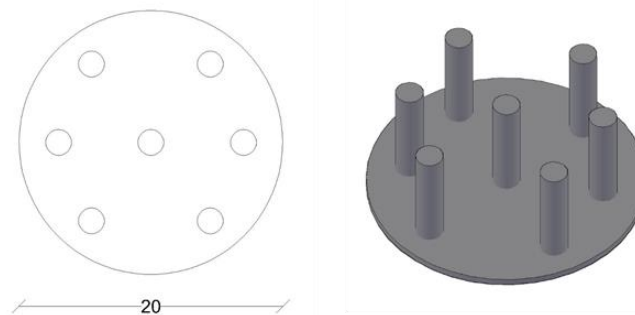

Figure 2. Vertical tubular baffle (VTB)

2.1 Internal reboiler prototype testing

Testing of internal reboiler prototypes is done by using the tool for heating water (material solution). The water filled in the boiler section is heated to provide hot steam which the heat will be transferred by the reboiler. The amount of water in the boiler is also fixed. The heating process is carried out with a heat source of LPG stove. Above the reboiler is filled with water (material solution) which receives heat from the reboiler tubes, with much determined where the tubes are submerged. The temperature at the heating process is assumed to be fixed, by regulating the size of the LPG stove at a fixed ignition position. Likewise, the pressure is also maintained by regulating the opening of the pressure valve.

There are many parameters was measured in the heating process such as:

1. Processing time is the time need for heating the water material from initial temperatur to 78°C, which is the temperature of the boiling point of bioethanol.
2. Temperature which measured at several points namely T1 is water temperature (material), T2 is reboiler tube temperature (Tre), T3 is steam temperature/boiler water surface (Tu) and T4 is internal plate surface temperature touched by fire.
3. Material unit weight (ρ) is the weight of the water unit (material solution) that is heated in a reboiler, and measured using a 10 ml pycnometer.
4. The volume of water in the boiler and water (material) reboiler, measured before the heating process for uniformity of the process in each treatment.

The experiment was arranged using a vertical tubular baffle heat exchanger with 9 variations, namely: A, B, C that were experiments with a tube height of 8 cm, a diameter of 2 cm and consisting of 3, 5, and 7 tubes, for ordinary water material. D, E, F were experiments with a tube height of 4 cm, a diameter of 4 cm and consisting of 3, 5, and 7 tubes for ordinary water material. While G, H, I were experiments with tube height of 4 cm, diameter of 4 cm and consisting of 3, 5, and 7 tubes, for water material with 10% ethanol.

2.2 Analysis of heat transfer process

According to Maraolis and Saravacos [8], the heating rate (heat load) of a heat exchanger (Q , kW), required to heat the product (m , kg/s) by a temperature difference (ΔT , K or °C), is estimated from the equation :

$$Q = m \cdot C_p \cdot \Delta T \quad (1)$$

Where, C_p (kJ/kg.°C) is spesific heat of the product. Temperature difference of product defined by equation :

$$\Delta T = T_2 - T_1 \quad (2)$$

The design and operation of heat exchanger is based on the overall heat transfer coefficient U , which is defined by generalized from equation :

$$\frac{Q}{A} = U \cdot \Delta T_m \quad (3)$$

Where U is the overall heat transfer coefficient ($\text{kW/m}^2 \cdot ^\circ\text{C}$), A is the heat transfer area (m^2) and ΔT_m is the logarithmic mean temperature difference. Hagan and Kruglov [9] stated these equation with $\frac{Q}{A} = U \times MTD$. The meaning of ΔT_m or mean temperature difference (MTD) is equal namely temperature difference, that defined by equation :

$$\Delta T_m = \frac{(T_s - T_1) - (T_s - T_2)}{\ln[(T_s - T_1)/(T_s - T_2)]} \quad (4)$$

Where T_1 is feed temperature, T_2 is target temperature and T_s is steam temperature.

3. Results and Discussion

The heat exchanger designed as an internal reboiler is a type of heat exchanger which is in direct contact, and the type is in the form of shell and tube, where the liquid/solution of the heated material is in the shell part and the heating steam is in the tube section. As stated by Singh [10] that in equipment involving the heat transfer process, in the heating process for the type of shell and tube, liquid heated material is in the shell, while the heating fluid is inside the tube.

3.1 Temperature distribution in each type of reboiler design

The mechanism of heat transfer that occurs in the vertical tubular baffle (VTB) heat exchanger design is the source of heat/energy (stove) transfers heat to the boiler (water), to produce steam that will heat the reboiler tubes. The reboiler tubes carry the heat from the steam boiler and transferred these to material (water) that is processed in the reboiler. The rate of transferred heat depends on several factors such as feed temperature and pressure, shell diameter, a number of tubes, tube geometry, baffle spacing and cutting spacing [12]. Figures 3, 4, and 5 show the temperature distribution in the water heating process using an internal reboiler that has been designed.

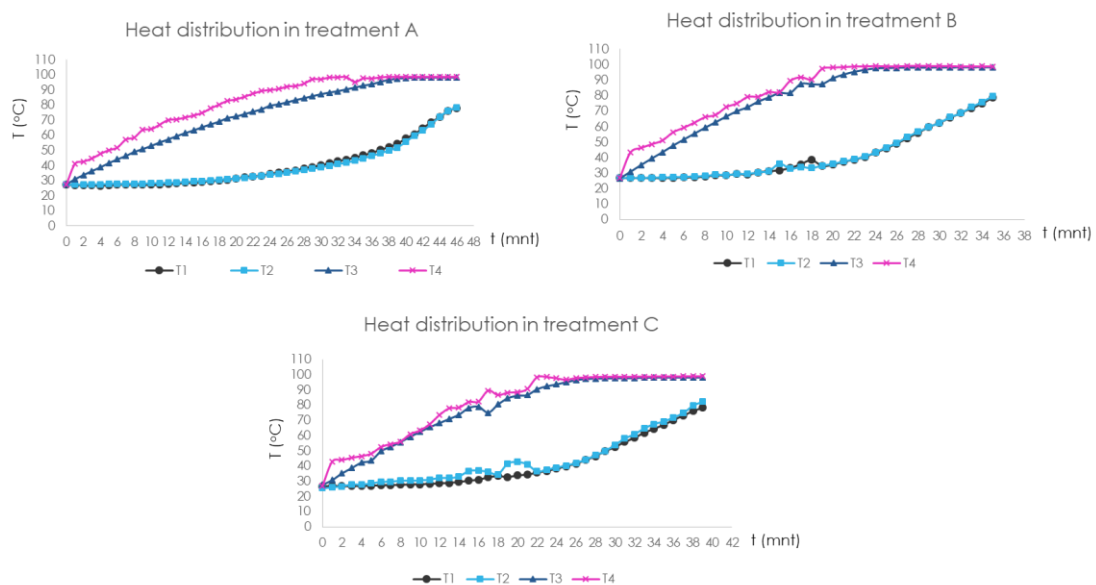

Figure 3. Heat distribution at high tube treatment is 8 cm and 2 cm in diameter where A consists of 3 tubes, B consists of 5 tubes and C consists of 7 for ordinary water material

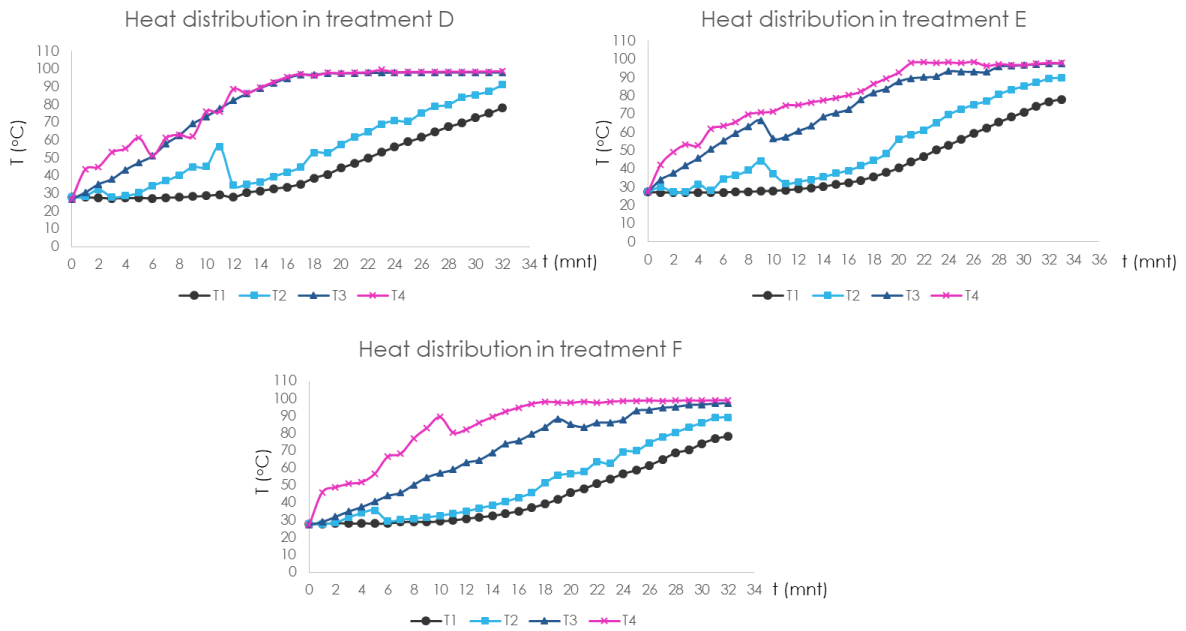

Figure 4. Heat distribution at high tube treatment is 4 cm and 4 cm in diameter where D consists of 3 tubes, E consists of 5 tubes and F consists of 7 for ordinary water material

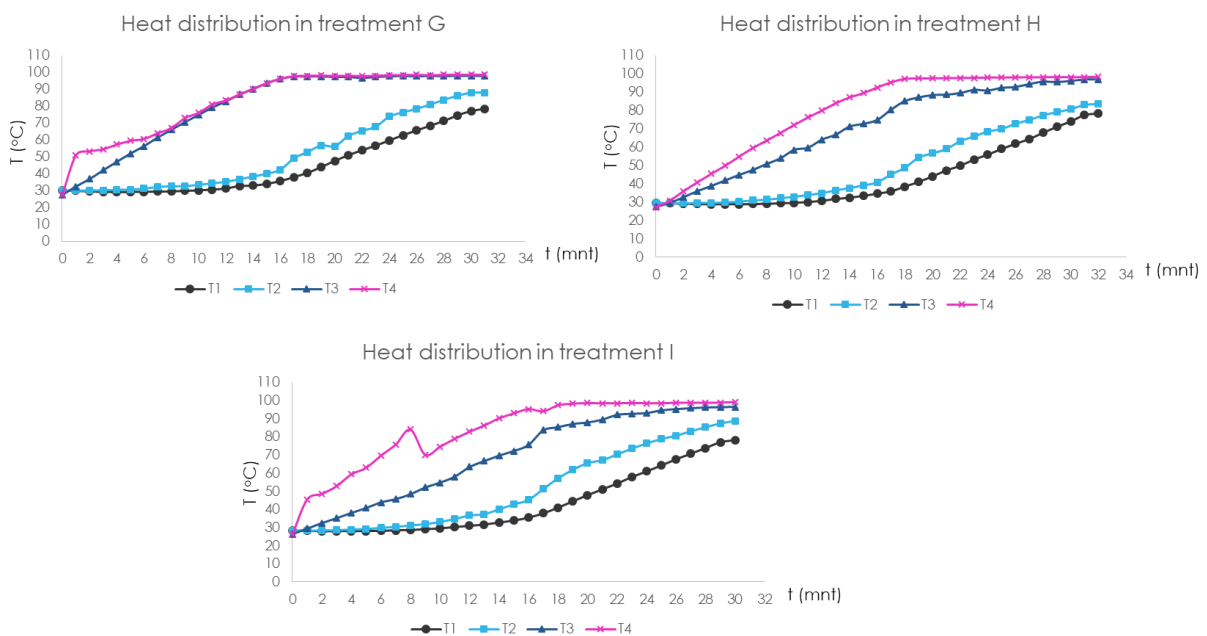

Figure 5. Heat distribution at high tube treatment is 4 cm and 4 cm in diameter where G consists of 3 tubes, H consists of 5 tubes and I consists of 7 for water material with 10% ethanol

The shape/geometry of a heat exchanger gives different performance. As shown by the image of the temperature distribution above, in a heat exchanger with a smaller tube diameter, will result in a

slower heating process. This is shown in treatments A, B, and C, for a rapid rise in temperature (40°C) occurs after 20 minutes, while for treatment D, E, F, G, H and I occur before the 20th minute. The temperature distribution process is strongly influenced by the movement of fluid/steam through the tube. The easier the process of movement of steam in the tube, the faster the temperature changes.

Based on the image, it is shown that T1 is the temperature of the heated material, and T3 is the steam temperature of the boiler. The value of T1 before and after the heating process is used to calculate the amount of heat needed for the heating process, as in equation (1) and (2). Other than that it is also used to calculate the value of MTD which is also influenced by the steam temperature of the boiler as in equation (4). Hagan and Kruglov [9] stated that since process-side temperature for the inled liquid and outlet streams (the vapour temperature is measured) are known, the reboiler MTD is known. With the installed area of heat-transfer surface also known, the prevailling overall heat transfer coefficient (U) can be easily calculated.

Figures 4 and 5 show the temperature distribution in heat exchanger with the same size and number of tubes, but different for the heated material. In Figure 4 the material used is ordinary water, while in Figure 5 the material used is water with 10% ethanol. Based on figures 4 and 5 it is known that material differences do not affect the temperature distribution characteristics, but there are differences in the time of achieving a temperature of 78°C, which is for materials containing 10% ethanol was faster heat compared to materials in the form of ordinary water. Likewise the value of U obtained is not significantly different from the difference in the heated material.

3.2 The performance of vertical tubular baffle (VTB) type heat exchangers in various treatments

Boiling water in the reboiler shows that the steam convect heat to the tube. The heat is then conducted through the tube and finally convected by boiling the water. In this condition, there is number U. This number called the overall heat transfer coefficient, is defined largely by the system, and in many cases it proves to be insensitive to operating conditions of the system [11]. The overall heat transfer coefficient U is either calculated from the overall thermal resistance of the heat exchanger, including fouling or taken from empirical data or measurements of a similar heat exchanger product system. The overall heat transfer coefficient refers normally to the internal surface of the tube or heated surface, which represents the major thermal resistance [8].

Table 1. The result of vertical tubular baffle reboiler experiment

Treatment	A (m ²)	Material volume (ml)	ρ (unit weight of material) (ml/g)	Processing times (sec)	Fuel needs (g)	U (watt/m ² °C)
A	0,021	3000	0,996	2730	80	0,268
B	0,030	3000	0,994	1801	60	0,299
C	0,039	3000	0,994	2319	60	0,173
D	0,022	3000	0,995	1895	80	0,381
E	0,032	3000	0,996	1946	80	0,260
F	0,042	3000	0,994	1891	60	0,206
G	0,022	3000	0,982	1824	60	0,386
H	0,032	3000	0,982	1879	60	0,268
I	0,042	3000	0,982	1765	60	0,221

Value of U in the Table 1, calculated using equation (1) and (3) using observational data. According to Table 1, the highest value of U is indicated by treatment D and G, namely with a tube height of 4 cm, a diameter of 4 cm and the number of tubes of 3 pieces. With the same surface area value A is smaller than D, so also the value of C is smaller than F. The value of U with the same area in B is greater than E. This shows that not only the surface area of the tube, as well as the height and diameter tube but the number of tubes for a certain height and diameter will give an optimal value. That is in accordance with the statement Hagan and Kruglov [9] that the maximum heat flux for nucleate boiling depends on the physical properties of the boiling fluid, and on the geometry of the heat exchanger. Tube length considers as an important factor in balancing pressure drop and heat transfer coefficient of shell and tube exchangers. Heat transfer coefficient and pressure drop increase as tube length increase [12].

4. Conclusion

Based on observations it was found that the different geometry of the vertical tubular baffle heat exchanger give different performance. Height, diameter, and the number of tubes (surface area) affect the value of the overall heat transfer coefficient, times and fuels needed for heating liquids at a temperature of 78 °C. In the same surface area but different height and diameter of this heat exchanger, give a different result in overall heat transfer coefficient (U). HE with the number of tubes 3 and 7 obtained a higher value of U with a tube height of 4 cm and a diameter of 4 cm, compared with the value of U in HE with a tube 8 cm in high and 2 cm in diameter, but the opposite occurs in HE with a number of tubes 5.

Acknowledgments

This research was supported by the Final Assignment Recognition Fund of Universitas Gadjah Mada. Our thanks and appreciation go to all the teams at the Food and Postharvest Engineering Laboratory, the Department of Agricultural and Biosystem Engineering, Faculty of Agricultural Technology, Universitas Gadjah Mada, which has helped in conducting research.

References

- [1] KLM 2013 Tecnology Group 2013 Reboiler Engineering Design Guidline
- [2] Bell JA, Bouck D, Farone JP, Flowers J, Grave E, Kister HZ and Y N 2011 Reboiler circuits for trayed columns *Chem. Eng.* **118**
- [3] Rahardjo B S B and S 1998 Koefisien perpindahan panas permukaan bola dengan aliran udara dalam pipa *Agritech* **18** 14–8
- [4] Committee F R I D P 2011 Reboiler Circuit For Trayed Columns *Chem. Eng.*
- [5] Bhanvase BA, Deosarkar MP, ShirsathSR and G R 2007 Internal reboiler in distillation column *Chem. Eng. World* **42** 86–8
- [6] Susilo S 2009 *Rancangan dan uji kinerja alat distilasi etanol dengan metode rektifikasi* (Bogor Agricultural University)
- [7] Loraine A. Huchler P E 1999 Managing Reboiler Steam-side Operation Improves Equipment Reliability and Steam Quality *MarTech Syst. Inc., Lawrenceville, New Jersey USA* 17
- [8] Maraolis ZB and S G 2003 *Food Process Design* (Marcel Dekker, Inc)
- [9] Hagan M D and Kruglov V N 2010 Understand heat flux limitations on reboiler design *Chem. Eng. Prog.* **106** 24–31
- [10] Singh P 2001 *Simulation of Kettle Reboiler* (University of Roorke)
- [11] Lienhard IV JH and Lienhard V JH *A Heat Transfer Textbook* (USA: Phlogiston Press Cambridge Massachusetts)
- [12] Abd A A, Kareem M Q and Naji S Z 2018 Performance analysis of shell and tube heat exchanger: Parametric study *Case Stud. Therm. Eng.* **12** 563–8