



# Characteristic of Fuzzy, ANN, and ANFIS for Brushless DC Motor Controller: An Evaluation by Dynamic Test

Widjonarko<sup>1</sup>, Andi Setiawan<sup>1</sup>, Bayu Rudiyanto<sup>2</sup>, Satryo Budi Utomo<sup>1</sup>,  
Muji Muji Setiyo<sup>3\*</sup>

<sup>1</sup>Faculty of Electrical and Electronic Engineering,  
Universitas Jember, Jl. Kalimantan No.37, Sumbersari, Kabupaten Jember 68121, INDONESIA

<sup>2</sup>Departement of Renewable Energy,  
Politeknik Jember, Lingkungan Panji, Tegalgede, Kec. Sumbersari, Kabupaten Jember 68124, INDONESIA

<sup>3</sup>Department of Automotive Engineering,  
Universitas Muhammadiyah Magelang, Jl. Bambang Sugeng km.05 Mertoyudan, Magelang 56172, INDONESIA

\*Corresponding Author

DOI: <https://doi.org/10.30880/ijie.2021.13.06.024>

Received 24 October 2020; Accepted 01 June 2021; Available online 31 August 2021

**Abstract:** Brushless DC (BLDC) motors are the most popular motors used by the industry because they are easy to control. BLDC motors are generally controlled by artificial controls such as Fuzzy Logic Controller (FLC), Artificial Neural Network (ANN), and Adaptive Neuro-Fuzzy Inference System (ANFIS). However, the performance of the BLDC control system in previous studies was compared separately with their respective parameters, making it difficult to evaluate comprehensively. Therefore, in order to investigate the characteristic performance of Fuzzy, ANN, and ANFIS, this article provides a comparison of these artificial controls. Two scenarios of the dynamic tests are conducted to investigate control performance under constant torque-various speed and constant speed-various torque. By dynamic testing, characteristics of Fuzzy, ANN, and ANFIS can be observed as real applications. The testing parameters are: Settling Time, Overshoot and Overdamp (in the graph and average value), and then statistic performance are: Integral Square Error (ISE), Integral Absolute Error (IAE), Integral Time Absolute Error (ITAE), and Mean Absolute Error (MAE). The test result in scenario 1 showed that the ANN has a better performance compared to other controllers with the MAE, IAE, ITAE, and ISE value of 31.3003; 105.6280; 208.0630; and 5,7289 e4, respectively. However, in scenario 2, ANN only has a better performance compared to other controllers on just a few parameters. In scenario 2, ANN is indeed able to maintain speed but it has a more ripple value than ANFIS. Even so, the ripple that occurs in ANN does not have too much value compared to the setpoint. Therefore, the MAE value of the ANN is smaller than the ANFIS (18.8937 of ANN and 28.4685 of ANFIS).

**Keywords:** BLDC, fuzzy, ANN, ANFIS, Speed motor controller

## 1. Introduction

The Brushless DC (BLDC) motor is one of the most popular motors used in modern automotive propulsion system, both for electric cars and electric motorcycles [1]–[3]. There are many reasons why the industry interested use BLDC motors than other motors, such as high torque, easy maintenance, low noise, high dynamic response, high efficiency, and easy speed control. Many researchers interest in BLDC which includes activities to make an efficient BLDC motor, hardware topology used to control the motor, and speed control strategy [4].

Lesson from previous studies [5]–[7], many strategies is used in controlling BLDC motors, especially concerning the intelligent controller that very popular today [8]–[10]. Several researchers reported the use of Fuzzy [11], [12], Artificial Neural Network (ANN) [13]–[15], ANFIS [16], [17], and its combination [4], [18], [19]. Despite analyzing the digital values, a Fuzzy Logic Controller (FLC) is generated by interpreting the analog or continuous values of 0 and 1. FLC works by assimilating expert human intelligence into a pattern that contains a relationship between inputs and outputs. The pattern of input and output is then subjected to fuzzy control rules (mostly conditional rules). The information process architecture of ANN has made it an advantageous property over classical controllers in control applications of non-linear and linear paradigms. Flexible learning and mapping of complex functional problems are the strengths of artificial neural networks of parallel distribution architecture. The ANFIS network is a hybrid network that combines two controllers: fuzzy logic and neural networks. These two controllers merge to create a single entity that improves the features of machine control over a single controller [20], [21]. Besides using a single controller to control a BLDC motor, some studies also compared speed control on a BLDC motor. Some of them are Krishna [22] Ahmed [23] and Varshney [24] who discussed the comparison between fuzzy logic and PI methods, as well as the combination of PID, Fuzzy Control, and ANFIS conducted by Ramesh [14].

However, the performance of the BLDC control system in previous studies was compared separately with their respective parameters, making it difficult to evaluate comprehensively. These various parameters include the BLDC motor used, the control system design used such as differences in Fuzzy membership, training data used in ANFIS and ANN controls, test scenarios, and parameters used to determine whether the control can work optimally or not. Therefore, it is necessary to compare the performance, especially in the control system as a comparison. With the same test parameters, the best control system will be easily identified [25], [26].

Therefore, our present study compares the intelligent control system into the same model to determine the existing intelligence control systems' performance. Then, the statistical parameters are applied to analyze the phenomenon from the obtained results [27], [28]. Two dynamic test scenarios on a BLDC motor are applied at various loads and conditions. In addition, the intelligent control system created in this study is trained with the same data. The data is extracted from the Fuzzy controller membership. Thus, the system will be able to find out the ideal performance with different controllers because it uses the same data source and also with the BLDC motor specifications. The present work differs from the previous test, where a static test was applied in the previous study [23], [29], [30]. This is well known that static testing is difficult to justify because it relies on one-step testing. In fact, in actual application, the control system works on load variations, such as speed fluctuation [31], both linear and nonlinear (increases and decreases randomly) as well as other dynamic tests such as physical loads or road terrain [32]. The testing parameters that include settling time, overshoot and overdamp (in the graph and average value); and also statistic performance include Integral Square Error (ISE), Integral Absolute Error (IAE), Integral Time Absolute Error (ITAE), and Mean Absolute Error (MAE) were chosen because it is considered to represent the overall performance.

## 2. Method

The control system used in this study is a closed-loop control system with two inputs and one output. The input data are errors and delta errors while the output is the amplitude values used to control the voltage source. The control system strategy is based on controlling the power of the BLDC motor. The BLDC motor specifications and the block diagram used are presented in Fig. 1 and Fig. 2, respectively.

Fig. 1 - BLDC motor specification

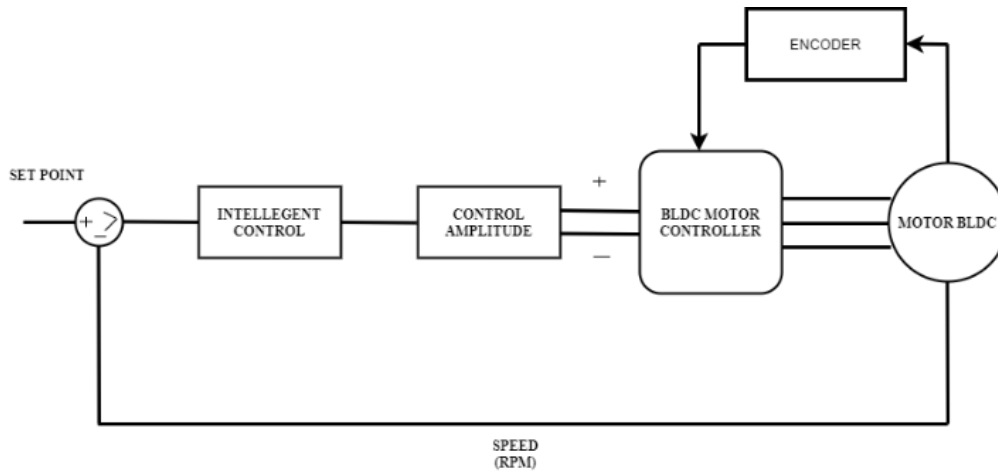

**Fig. 2 - BLDC speed controller diagram block**

In this BLDC motor speed control system, there is an encoder block to adjust the phase control signal between the motor and the BLDC motor controller (inverter motor). With this block, the phase signal adjustment control is replaced by an amplitude control. Because of the closed-loop, the system must be designed to use control intelligence so that it can work as intended. The input of this system consists of two inputs, a reference for the setpoint and the feedback from the motor when it is controlled in the form of speed value (rpm). The input value used is formulated by Equation (1) and Equation (2).

$$e = Ref - Feedback \tag{1}$$

$$de = e_{(t-1)} - e_o \tag{2}$$

In the input equation, it can be seen that  $e$  = error,  $Ref$  is the reference (setpoint), and  $Feedback$  is the output value of the motor. At the same time,  $de$  is the delta error,  $e_{(t-1)}$  is the previous error value, and  $e_o$  is the current error value. For intelligence output, control is the value that will be used to control the voltage source. Since the loop is closed, the output is obtained using Equation (3).

$$Out = Out_{(t-1)} + Out_o \tag{3}$$

From Equation (3), it can be seen that  $Out$  = output value,  $Out_{(t-1)}$  is the previous output value, and  $Out_o$  is the current output value. This system design uses three different intelligence control systems, namely Fuzzy, ANN, and ANFIS, while those control design with same of the control block model that can be seen in Fig. 3. The reason why the control block model is designed with the same block because these intelligent controls are has the same characteristics. The same characteristics are that the controls must have minimal two inputs in their input block, so it must be added to the value of the previous output, or it is called a delta error in closed-loop control [25].

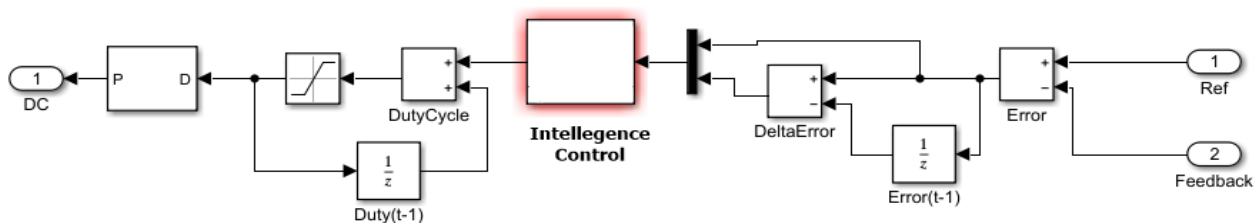
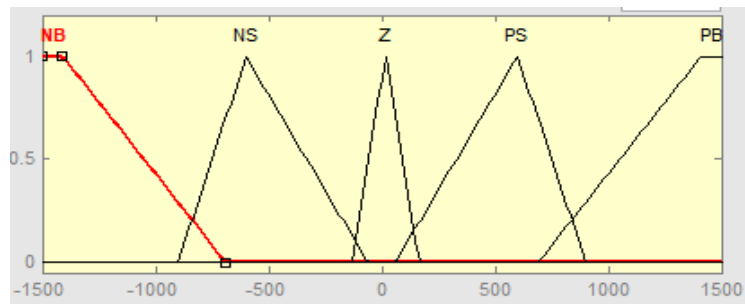

**Fig. 3 - Control block design in detail**

## 2.1 Intelligent Control Design

The first controller is the Fuzzy control system. As mentioned in the control strategy before that in this paper, the system must build by using a closed-loop controller. To use the Fuzzy control system requires tuning for fuzzy input cations, namely errors, delta errors, and amplitude as the output parameter. The design of the membership of the Fuzzy Controller is presented in Fig. 4, Fig. 5, and Fig. 6. Meanwhile, Fuzzy rules are presented in Table 1. The membership

of error in this work from -1500 to 1500, membership delta error from -100 to 100, and for membership of amplitude from -1 to 1.



**Fig. 4 - Membership input error**

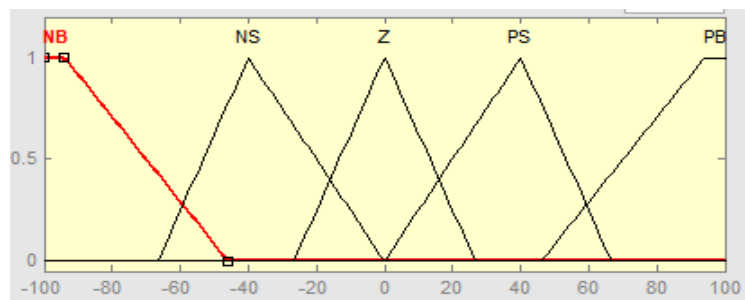

**Fig. 5 - Membership input delta error**

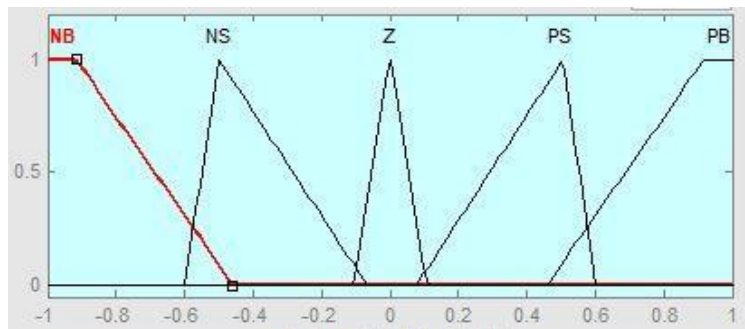

**Fig. 6 - Membership output amplitude**

**Table 1 - Fuzzy rule**

D/DE	NB	NS	Z	PS	PB
NB	NB	NB	NS	NS	Z
NS	NB	NS	NS	Z	PS
Z	NS	NS	Z	PS	PS
PS	NS	Z	PS	PS	PB
PB	Z	PS	PS	PB	PB

The second is ANN control. Before being able to use ANN, the ANN control system is necessary to design the specific structure and then continue to the training process. The ANN network structure is presented in Fig. 7, where ANN is formed with two layers consisting of 50 neurons in layer 1 and 1 neuron in layer 2.

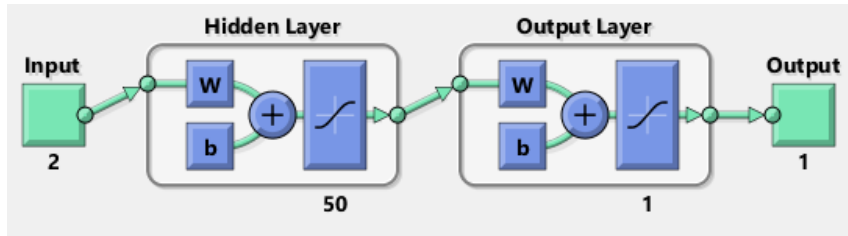

Fig. 7 - Architecture ANN controller used in this study

The ANN is trained to use data extracted from Fuzzy membership, so the amount of data obtained is 227 x 2 for input, and 227 x 1 for output. For extracting the data from the fuzzy control, we use the extractor scheme as presented in Fig. 8. The input of the extractor is a sinus signal with amplitude value that has the same value as each parameter in membership of Fuzzy input (minimum and maximum range of membership input). At the same time, the frequency of each signal has a different value. For the error input, it has frequency extracting 3000Hz. For the delta error input, it has frequency extracting 100Hz. Then, when the extractor runs, all parameter is logged into the scope. The example of the data extracted to be used as training data is presented in Table 2. The output of ANN is only one, namely the amplitude. The results of the ANN training process that have been carried out have an accuracy of 99.67% of all data that has been trained by regression validation techniques.

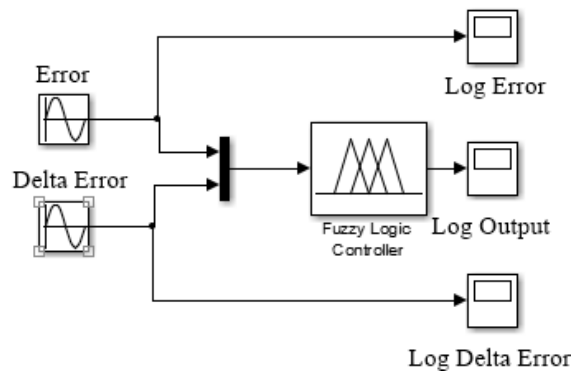
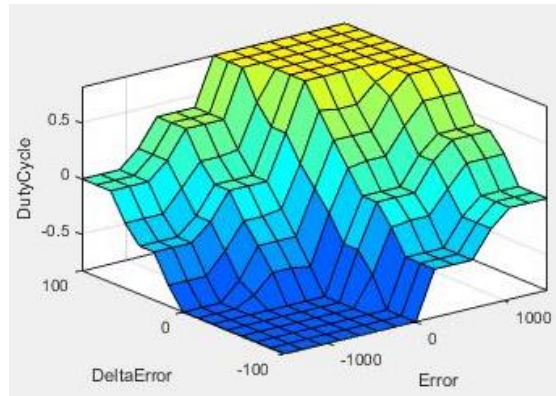

Fig. 8 - Simulink circuit for closed-loop rule extractions

Table 2 - Data training used for ANN and ANFIS

No	Input		Output
	Error	Delta Error	
1	0	0	-0.0000694
2	43.1356	86.3433	0.8116
3	86.2356	-87.1142	-0.7494
4	129.2642	1.5847	0.2772
5	172.1869	85.517	0.7569
6	214.9653	-87.8642	-0.3548
...	...	...	...
226	280.4208	91.7419	0.7774
227	322.6800	-11.9225	0.2915

The last is the ANFIS. Basically, ANFIS has the same necessary to use as ANN. That necessary is about needed for to be trained before it is used. So in this stage, ANFIS trained with the same data as ANN. The ANFIS training result is the average error from the data train output in Table 2 with the value of 0.10868. This value comes after we subtract the output value of the ANFIS model that has been trained with the value that must be produced according to Table 2 (output column). The output of the ANFIS controller is presented in Fig. 9.



**Fig. 9 - ANFIS rule output**

### 2.2 Dynamic Test Scenario

In this work, our research is done by simulation using Simulink Matlab. For evaluating and comparing the performance of the intelligence controls, the two test scenarios were conducted. For scenario 1, the speed changes with a fixed torque (0.6 N.m), then for the second test, the speed is constant (2500 rpm), but the torque changes. In scenario 1, the system changes the motor speed (setpoint) in a fixed torque to evaluate the ability of the system to achieve a steady-state. The motor speed set on 500 rpm up to 3500 rpm, increase per 500 rpm. Then, the speed was reduced from 3500 rpm to 500 rpm, by an interval of 500 rpm. Finally, it continues by random mode from 500 rpm to 1500 rpm, back to 500 rpm, and then to 2000 rpm. In scenario 2, we change the torque (motor load) with a fixed speed input. The purpose of this test is to investigate the ability of the system to stabilize the speed conditions. The order of torque transfer in this test is as follows 0.5, 1, 2, 3, 2, 1, 0.5, 3, 0.5, 3, 0.5 Nm.

### 3. Result and Discussion

This study aims to assess the response of the system and its stability. After knowing the results, it is analyzed using several parameters. The testing parameters are: Settling Time, Overshoot and Overdamp (in the graph and average value), and then statistic performance are: Integral Square Error (ISE), Integral Absolute Error (IAE), Integral Time Absolute Error (ITAE), and Mean Absolute Error (MAE) [27], [28].

Using scenario 1, we found that the ANN has the best average rise time value compared to the others. For Rise time value, ANN has 1.59 times better performance compared to ANFIS and 1.03 times better than Fuzzy. This means that ANN has faster or more responsive compared to other control systems. However, in terms of speed to arrive at the setpoint, ANN requires an average time of 0.01999 seconds, Fuzzy of 0.0264 seconds, and ANFIS of 0.03231 seconds. If each control system is compared from the overshoot or overdamps side, it can be concluded that ANFIS has a fairly small value compared to Fuzzy and ANN (3.72 times better than Fuzzy and 3.38 times better than ANN). However, ANFIS and ANN have a difference in the value of 6.21%. Also, parameter statistics show that ANN has the best value than the other. It can know by looking at the smallest error value produce. By evaluate this parameter, the ANN in scenario 1 achieves a small error from setpoint value (MAE), low overshoot and oscillations (ITAE), and low ripple all of the running time (ISE and IAE). The characteristic of response systems for Fuzzy, ANN, and ANFIS using scenario 1 are presented in Fig. 10, Fig. 11, and Fig. 12, respectively. Meanwhile, the comparison of setting time and overshoot for each control are presented in Fig. 13 and Fig. 14, respectively.

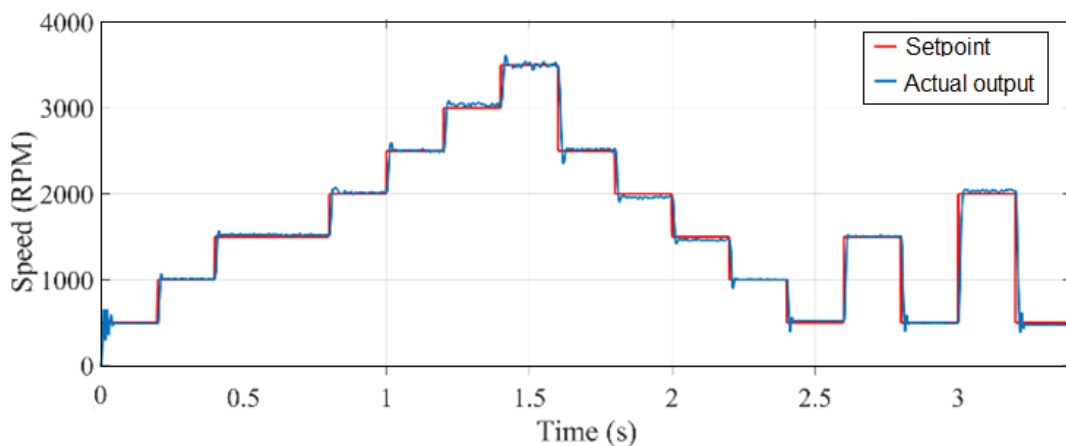

**Fig. 10 - Fuzzy response system in scenario 1**

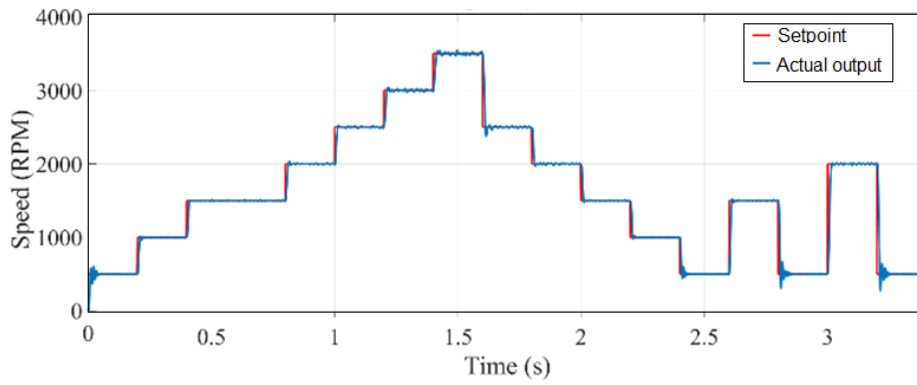

Fig. 11 - ANN response system in scenario 1

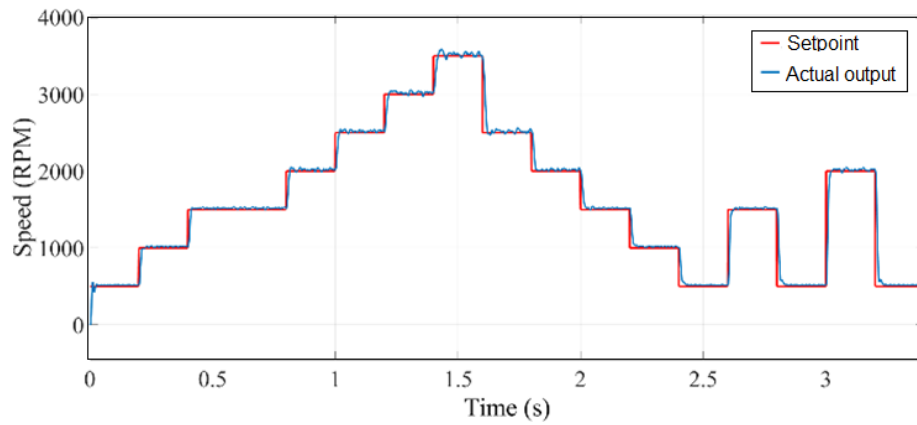

Fig. 12 - ANFIS response system in scenario 1

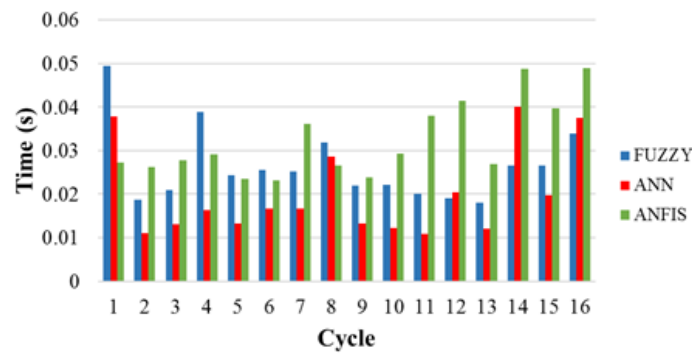

Fig. 13 - Comparison of settling time for each intelligence control in scenario 1

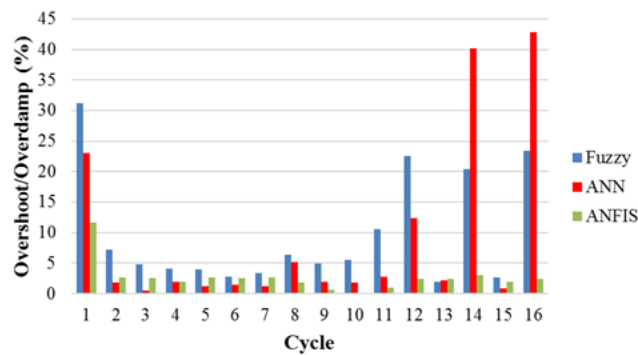

Fig. 14 - Overshoot comparison for each intelligence control in scenario 1

Then, to make the analysis more accessible, all information on scenario 1 is presented in Table 3. In this table, all data such as average settling time cycles, average overshoot cycle, and all the parameter statistics are display clearly.

**Table 3 - Recapitulation of all performance in scenario 1**

Parameter	Fuzzy	ANN	ANFIS
Average settling time (s)	0.0264	0.01999	0.03231
Average Overshoot (%)	9.7269	8.823	2.6125
ISE	6,2140 e4	5,7289 e4	6,6832 e4
IAE	156.3967	105.6280	162.7551
ITAE	277.4092	208.0630	308.6756
MAE	46.2236	31.3003	48.0948

The next stage is testing using scenario 2. In scenario 2, the system gave the command to maintain the specific speed. Then, the torque (motor load) was changed to evaluate the stability produces by the control system. Response systems for Fuzzy, ANN, and ANFIS using scenario 2 are presented in Fig. 15, Fig. 16, and Fig. 17, respectively. Meanwhile, the comparison data is presented in Table 4.

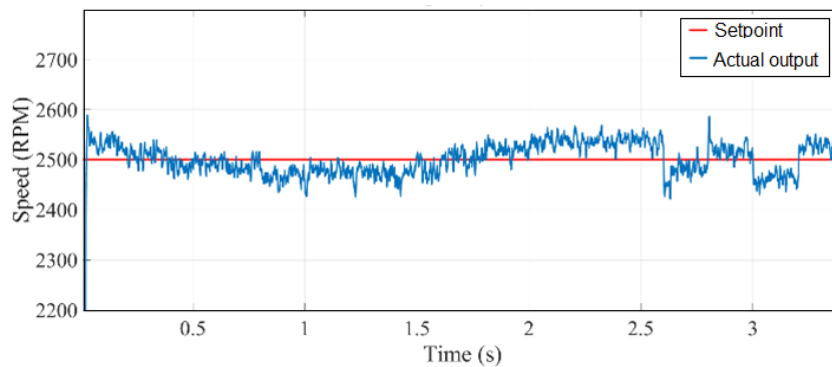

**Fig. 15 - Fuzzy response system in scenario 2**

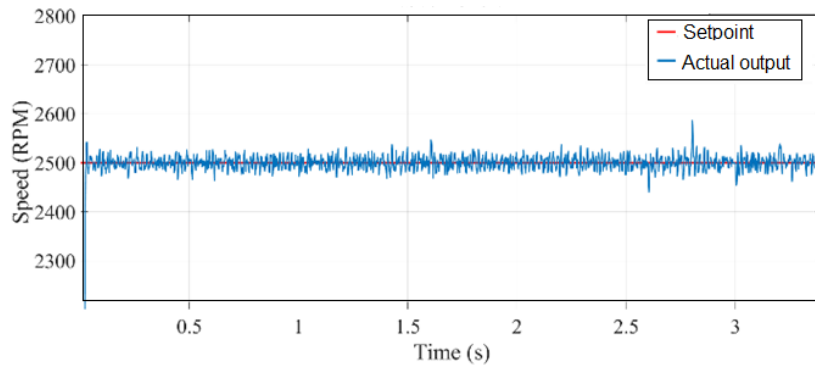

**Fig. 16 - ANN response system in scenario 2**

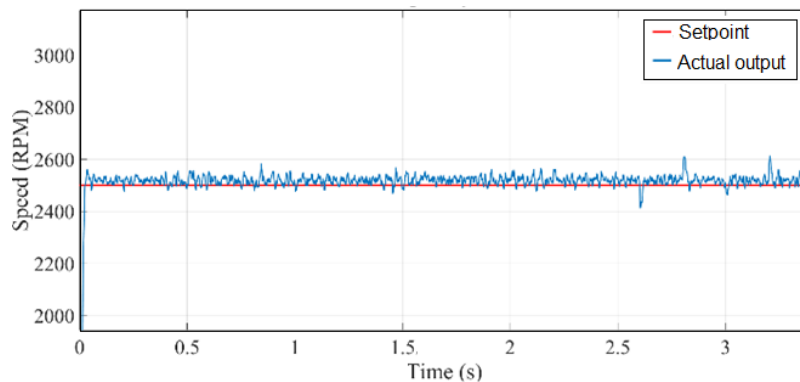

**Fig. 17 - ANFIS response system in scenario 2**



**Table 4 - Recapitulation of all performance in scenario 2**

Parameter	Fuzzy	ANN	ANFIS
ISE	5,3391 e4	6,0048 e4	4,5328 e4
IAE	128.1557	64.1608	96.6886
ITAE	178.8493	54.9818	126.9212
MAE	37.7189	18.8937	28.4685

In scenario 2, ANN also has an excellent performance in several parameters. It can be seen in the response signal shown in Fig.s 15 to Fig. 17 and the statistics parameter in Table 4. In the response system, it can be analyzed that Fuzzy has an unstable response during the testing. In contrast, ANN and ANFIS produce more stable responses in different torque (motor load). However, to investigate the quality of the control system, ANN and ANFIS performance can be concluded by analyzing the statistics parameter in Table 4. In the ISE parameter, the ANFIS has a lower value than the ANN, so it means that ANFIS better than the ANN. The better performance shown by the ISE parameter is the ripple value during the test. Because the ANFIS has a lower ISE value, it means that ANFIS has more stabilize than ANN. It also can be analyzed when evaluating the response system that ANFIS tends to have a low ripple than ANN. However, another parameter such as IAE, ITAE, and MAE, ANN has better value than ANFIS, for example, in the MAE parameter.

#### 4. Conclusion

In this study, we have compared the use of an intelligence controller on the BLDC motor using data extraction from one of the intelligence controllers. The test was carried out by two scenarios, and analyzing the results of the system response was carried out by graph and some statistical parameters such as MAE, IAE, ITAE, and ISE. We found in scenario 1, ANN has a better performance compared to other controllers with the MAE, IAE, ITAE, and ISE value of 31.3003; 105.6280; 208.0630; and 5,7289 e4, respectively. However, in scenario 2, ANN only has a better performance compared to other controllers on just a few parameters. In scenario 2, ANN is indeed able to maintain speed but it has a more ripple value than ANFIS. Even so, the ripple that occurs in ANN does not have too much value compared to the setpoint. Therefore, the MAE value of the ANN is smaller than the ANFIS (18.8937 of ANN and 28.4685 of ANFIS). Our next recommendation research to get better performance is by implementing an optimization method to optimize all intelligence control parameters, such as a membership function in Fuzzy, amount of neuron in ANN or by online tuning when the system runs.

#### References

- [1] Naresh, K., Rambabu, M., Balaji, A., & Raju, G. N. (2018) 'Impedance Source Inverter Fed Permanent Magnet BLDC Motor', *IUP Journal of Electrical & Electronics Engineering*, 9(4), pp. 33–46
- [2] Suganyadevi, M. V., Ajay, D. L. L., Ananth, T., Balaji, N., & Mathavan, K. (2020) 'Design and Development of SEPIC Converter Fed BLDC Motor Drive for Photovoltaic Application', *International Journal of Advance Science and Technology*, 29(10), pp. 3153–3163
- [3] Setiawan, I. C. (2019) 'Policy Simulation of Electricity-Based Vehicle Utilization in Indonesia (Electrified Vehicle - HEV, PHEV, BEV and FCEV)', *Automotive Experiences*, 2(1), pp. 1–8. doi: 10.31603/AE.V2I1.2020
- [4] Anshory, I., Robandi, I., & Ohki, M. (2019) 'System Identification of BLDC Motor and Optimization Speed Control Using Artificial Intelligent', *International Journal of Civil Engineering and Technology (IJCIET)*, 10(07), pp. 1–13
- [5] Kalam, A., & Siddiqui, S. A. (2018) *Intelligent Computing Techniques for Smart Energy Systems*
- [6] Tutaj, A., Drabek, T., Dziwinski, T., Baranowski, J., & Piatek, P. (2018) 'Unintended synchronisation between rotational speed and PWM frequency in a PM BLDC drive unit', *2018 23rd International Conference on Methods & Models in Automation & Robotics (MMAR)*, pp. 959–964
- [7] Poompavai, T., & Kowsalya, M. (2019) 'Control and energy management strategies applied for solar photovoltaic and wind energy fed water pumping system : A review', *Renewable and Sustainable Energy Reviews*, 107, pp. 108–122. doi: 10.1016/j.rser.2019.02.023
- [8] Muntashir, A., Purwanto, E., Sumantri, B., FAKhruddin, H. H., & Apriyanto, R. A. N. (2021) 'Static and Dynamic Performance of Vector Control on Induction Motor with PID Controller: An Investigation on LabVIEW', *Automotive Experiences*, 4(2), pp. 83–96. doi: 10.31603/ae.4812
- [9] Idir, A., Kidouche, M., Bensafia, Y., Khettab, K., & Tadjer, S. A. (2018) 'Speed control of DC motor using PID and FOPID controllers based on differential evolution and PSO', *International Journal of Intelligent Engineering and Systems*, 11(4), pp. 241–249. doi: 10.22266/ijies2018.0831.24

- [10] Widjonarko C., Avian, S., Utomo, B., Setiawan, A. & Rudiyanto, B. (2020) 'A control strategy for hybrid energy source in backbone base transceiver station using artificial neural network: a case study of Penajam, Indonesia', *International Journal of Energy and Environmental Engineering*, (June). doi: 10.1007/s40095-020-00348-y
- [11] Mitra, S., & Ojha, A. (2019) 'Performance Analysis of BLDC Motor Drive Using PI and Fuzzy Logic Control Scheme', *International Research Journal of Engineering and Technology(IRJET)*, 2(6), pp. 916–922
- [12] Zaid, M., & Sarwer, Z. (2018) 'Speed Control of PMBLDC motor using Fuzzy Logic Controller in Sensorless mode with Back EMF Detection', *Applications of Artificial Intelligence Techniques in Engineering*, 698, pp. 437–447. doi: 10.1007/978-981-13-1819-1
- [13] Babitha, S., Kulkarni, V., & Koujalagi, J. P. (2019) 'Vector Control Based Speed and Flux estimation in Switched Reluctance Motor Using ANN Controller', *2019 4th IEEE International Conference on Recent Trends on Electronics, Information, Communication and Technology, RTEICT 2019 - Proceedings*, pp. 10–14. doi: 10.1109/RTEICT46194.2019.9016823
- [14] Hassan, A. K., Elksasy, M. S., Saraya, M. S., & Areed, F. F., (2018) 'Brushless DC Motor Speed Control using PID Controller, Fuzzy Controller, and Neuro Fuzzy Controller', *International Journal of Computer Applications*, 180(30), pp. 47–52. doi: 10.5120/ijca2018916783
- [15] Mamadapur, A., & Mahadev, G. U. (2019) 'Speed Control of BLDC Motor Using Neural Network Controller and PID Controller', *2019 2nd International Conference on Power and Embedded Drive Control (ICPEDC)*, pp. 146–151
- [16] Yashoda, M., & Chandra Sekhar, O. (2016) 'Design and Analysis of ANFIS based BLDC Motor', *Indian Journal of Science and Technology*, 9(35). doi: 10.17485/ijst/2016/v9i35/97010
- [17] Joseph, T. S. S. S., Agees, J. C. & Prem, K. K. (2016) 'Novel bacterial foraging-based ANFIS for speed control of matrix converter-fed industrial BLDC motors operated under low speed and high torque', *Neural Computing and Applications*, 29(1411). doi: 10.1007/s00521-016-2652-6
- [18] Yang, W., Zhang, X., Tian, Y., Wang, W., Xue, J. H., & Liao, Q. (2019) 'Deep Learning for Single Image Super-Resolution: A Brief Review', *IEEE Transactions on Multimedia*, 21(12), pp. 3106–3121. doi: 10.1109/TMM.2019.2919431
- [19] Gobinath, S., & Madheswaran, M. (2020) 'Deep perceptron neural network with fuzzy PID controller for speed control and stability analysis of BLDC motor', *Soft Computing*, 24(13), pp. 10161–10180. doi: 10.1007/s00500-019-04532-z
- [20] Zaidan, M. R. (2018) 'Impact of artificial neural network for DC motor speed control over the conventional controller', *Journal of Engineering and Applied Sciences*, 13(21), pp. 9156–9163. doi: 10.3923/jeasci.2018.9156.9163
- [21] Jilani, A., Murawwat, S. & Jilani, S. O. (2015) 'Controlling Speed of DC Motor with Fuzzy Controller in Comparison with ANFIS Controller', *Intelligent Control and Automation*, 06(01), pp. 64–74. doi: 10.4236/ica.2015.61008
- [22] Krishna Veni, K. S., Senthil Kumar, N., & Senthil Kumar, C. (2019) 'A comparative study of universal fuzzy logic and PI speed controllers for four switch BLDC motor drive', *International Journal of Power Electronics*, 10(1–2), pp. 18–32. doi: 10.1504/IJPELEC.2019.096805
- [23] Ahmed, A. H., Kotb, A. E. S. B. & Ali, A. M. (2018) 'Comparison between fuzzy logic and PI control for the speed of BLDC motor', *International Journal of Power Electronics and Drive Systems*, 9(3), pp. 1116–1123. doi: 10.11591/ijpeds.v9n3.pp1116-1123
- [24] Varshney, A., Gupta, D., & Dwivedi, B. (2017) 'Speed response of brushless DC motor using fuzzy PID controller under varying load condition', *Journal of Electrical Systems and Information Technology*, 4(2), pp. 310–321. doi: 10.1016/j.jesit.2016.12.014
- [25] Widjonarko, Soenoko, R., Wahyudi, S., & Siswanto, E. (2019) 'Comparison of intelligence control systems for voltage controlling on small scale compressed air energy storage', *Energies*, 12(5), pp. 25–28. doi: 10.3390/en12050803
- [26] Usha, S., Singh, P., Geetha Shivam, A., Vaishnav, H., & Thentral, T. M. T. (2020) 'Performance Analysis of Different Speed Control Techniques for BLDC Motor', *International Journal of Advance Science and Technology*, 29(10), pp. 3642–3658
- [27] Marzaki, M. H., Tajjudin, M., Rahiman, M. H. F., & Adnan, R. (2015) 'Performance of FOPI with error filter based on controllers performance criterion (ISE, IAE and ITAE)', *2015 10th Asian Control Conference: Emerging Control Techniques for a Sustainable World, ASCC 2015*, pp. 5–10. doi: 10.1109/ASCC.2015.7244851
- [28] Özdemir, M. T., & Öztürk, D. (2017) 'Comparative performance analysis of optimal PID parameters tuning based on the optics inspired optimization methods for automatic generation control', *Energies*, 10(12). doi: 10.3390/en10122134

- [29] Usman, A., & Rajpurohit, B. S. (2017) 'Speed control of a BLDC Motor using Fuzzy Logic Controller', *1st IEEE International Conference on Power Electronics, Intelligent Control and Energy Systems, ICPEICES 2016*, pp. 1–6. doi: 10.1109/ICPEICES.2016.7853304
- [30] Potnuru, D., Alice Mary, K., & Sai Babu, C. (2019) 'Experimental implementation of Flower Pollination Algorithm for speed controller of a BLDC motor', *Ain Shams Engineering Journal*, 10(2), pp. 287–295. doi: 10.1016/j.asej.2018.07.005
- [31] Nguyen, T. S., Song, J., Yu, L., Fang, S., Tai, Y., & Lu, Z. (2019) 'Design and development of a real-time simulation and testing platform for a novel seamless two-speed transmission for electric vehicles', *Journal of Dynamic Systems, Measurement and Control, Transactions of the ASME*, 141(2). doi: 10.1115/1.4041358
- [32] Zeng, F., Yan, C., Wu, Q., & Wang, T. (2020) 'Dynamic behaviour of a conveyor belt considering non-uniform bulk material distribution for speed control', *Applied Sciences (Switzerland)*, 10(13). doi: 10.3390/app10134436