

Utilization of Excess Steam from a Vent Valve in a Geothermal Power Plant

by Bayu Rudianto

Submission date: 21-Mar-2023 03:31PM (UTC+0700)

Submission ID: 2042529243

File name: 1-s2.0-S2772427122000699-main_2_-_Dr._Bayu_Rudiyanto.pdf (1.54M)

Word count: 8432

Character count: 42431



Utilization of Excess Steam from a Vent Valve in a Geothermal Power Plant

Putri Sundari^a, Prihadi Setyo Darmanto^b, Bayu Rudiyanto^{c,*}, Miftah Hijriawan^d



^aDepartement of Mechanical Engineering, Faculty of Engineering, Universitas Gresik, Jl. Arif Rahman Hakim Gresik No.2B, Kramatandap, Gresik 61111, Indonesia

^bFaculty of Mechanical and Aerospace Engineering, Institut Teknologi Bandung, Jl. Ganesha 10, Bandung 40132, Indonesia

^cEnergy Engineering Laboratory, Departement of Renewable Energy Engineering, Politeknik Negeri, Jember, Jl. Mastrip 164, Jember 68121, Indonesia

^dGraduate Program of Mechanical Engineering, Universitas Sebelas Maret, Jl. Ir. Sutami 36, Surakarta 57126, Indonesia

ARTICLE INFO

Keywords:

Dry-steam cycle

Binary cycle

Kalina cycle

Excess steam

LEGC

Capacity factor

ABSTRACT

A novel strategy is presented for the utilization of the excess steam released into the atmosphere from the vent valve in a geothermal power plant. In particular, three possible approaches are considered: dry-steam cycle, binary cycle, and Kalina cycle. Thermodynamic models of these different power cycles are defined accordingly. The simulations are carried out using Aspen HYSYS®, used to solve the corresponding mass and energy balance equations. The feasibility and advantages of the different approaches are discussed from different points of view, i.e., energy, net power, and overall efficiency. Moreover, exergy analysis is used to identify the location, magnitude, and origin of thermodynamic inefficiencies. Economic aspects are also considered in terms of electricity or leveled electricity generating cost (LEGC) for the three considered cycles. Performances are quantified in terms of Capacity Factor (CF), the ratio between the actual power produced by the generator in a given period and the maximum output power that can be achieved according to the design capacity. The environmental impact is also considered.

Introduction

Geothermal energy is a type of renewable energy which is derived from steam vapor within the sub-surface of the earth and can be transformed into electricity. The conversion of geothermal energy into electrical energy is neither a cheap nor a simple process. Therefore, there is a real need to use the available energy efficiently [1–3]. By far, there are three different types of geothermal power plants which are (1) the flash cycle, (2) the dry-steam cycle, and (3) the binary-Kalina cycle [4].

Compared with other geothermal cycles, the dry-steam cycle is relatively simple with a less complicated component so that the cost can be lower than other cycles [5]. Furthermore, the dry-steam cycle contains more thermal energy due to the rich vapor condition of the steam, and it results in higher electricity production [6]. However, geothermal with dry-steam is very limited, estimated at 5% of all hydrothermal systems with temperatures above 200°C [7]. Therefore, improvement of the currently operating dry-steam cycle is necessary for sustainable electricity generation [8].

Some literature reported that the operating dry-steam cycle potentially causes significant losses due to excess steam release in the vent valve component [9,10]. The dry-steam from the production well in the geothermal power plant is received by a steam receiving header (SRH), equipped with an exhaust valve, before entering into the generating unit to control the incoming pressure within 6.5 bars, under the flow rate

needed. Meanwhile, the mechanism involves controlling the valve that functions at all times to remove the excess steam into the environment due to the contract Steam Purchase Agreement. The 10% surplus of supply aims to compensate for the load of electricity fluctuations in the interconnection network.

Other issues that should be discussed include plant sustainability because of the condition of the geothermal reservoir, which has depreciated over the operating period of more than 30 years. Suryadarma et al. reported a decrease in the temperature of 19°C (0.7°C/year) from the initial 245°C, the pressure drops from 34 to 9.3 bar, and the steam flow rate diminishes up to 3% per year [11]. This situation, therefore, requires that maximum utility of existing steam is a strategic road map to ensure sustainability in futuristic electricity production.

Several studies have focused on applying the excess steam from the vent valve in smaller-scale geothermal power plants. Prananto et al. researched by utilizing steam from the vent as a supply for the dry-steam cycle, using a variation of the gas removal system (GRS) to generate 15.94 MW of additional electricity [10]. Furthermore, Pratama also designed and simulated the operation of the Kalina cycle by utilizing the exhaust steam from the vent valve, producing optimal power by up to 4,251.72 kW, with an Ammonia mass fraction of 84% and pressure of 35 bars [12]. However, in previous research, the use of excess steam as a geothermal power plant only focused on how much power is generated

* Corresponding author.

E-mail address: bayu_rudianto@polije.ac.id (B. Rudiyanto).

<https://doi.org/10.1016/j.nexus.2022.100114>

Received 11 April 2022; Received in revised form 24 June 2022; Accepted 6 July 2022

Available online 15 July 2022

2772-4271/© 2022 The Author(s). Published by Elsevier Ltd. This is an open access article under the CC BY-NC-ND license

(<http://creativecommons.org/licenses/by-nc-nd/4.0/>)

Nomenclature

\bar{c}	specific heat capacity (J/kg.K)
e	specific exergy (kJ/kg)
\dot{E}	exergy flow (kJ)
h	enthalpy (kJ/kg)
I	irreversibility (kW)
\dot{m}	mass flow rate (kg/s)
η	efficiency (%)
N	NCG fraction (%)
P	pressure (bar)
s	entropy (kJ/kg.K)
T	temperature (°C)
ΔT_{pp}	pinch point temperature (°C)
W	power/work (kW)
y	exergy destruction ratio

Abbreviation

CATT	computer-aided thermodynamic table
CF	capacity factor
FCI	fixed capital investment
GRS	gas removal system
LEGC	levelized electricity generating cost
LMTD	log mean temperature difference
LRVP	liquid ring vacuum pump
MCWP	main cooling water pump
NCG	non condensable gas
ORC	organic rankine cycle
PEC	purchased equipment cost
REFPROP	reference fluid thermodynamic and transport properties
SRH	steam receiving header
TCC	total capital cost
TCI	total capital investment
TIP	turbine inlet pressure

by a cycle designed based on energy analysis (1st Law of Thermodynamics) without considering the exact losses that would occur in a system.

Exergy analysis can be used to complete and optimize the thermal cycle analysis. This method will obtain an accurate analysis of the type, cause, and location of losses so that improvements can be made to get an optimal cycle design. Besides that, the performance of geothermal power plants and economic aspects are an absolute prerequisite to be evaluated in planning a power plant project, followed by environmental factors that must be considered along with the issue of global warming [1,13–16].

Furthermore, this research analyzes the utilization of excess steam for small-scale geothermal power plants using three different cycles, namely the dry-steam cycle, the binary cycle, and the Kalina cycle. The analysis will be carried out based on four criteria that are prerequisites for the feasibility of a power plant, including thermodynamic analysis to know which cycle is the most efficient and produces the greatest power, analysis of plant performance that can be known by the value of Capacity Factor (CF), economic analysis by comparing Levelized Electricity Generating Cost (LEGC) generated from each cycle, as well as an analysis of the environmental impacts of plant operations.

Cycle Modeling in Geothermal Power Plants

Aspen HYSYS® carried out the simulation to modeling three different geothermal power plants and obtained the state properties corresponding with mass and energy balance. Furthermore, the data required was taken directly from the 24-h Log Operation History in the dry-steam power plant control room. This data also consists of assumptions based on the manual book in Engineering Department, as shown in Table 1.

5 In this study, we assumed no heat loss from the heat exchanger utilities to the environment. Moreover, the potential and kinetic energy were neglected.

Dry-steam Cycle Modeling

The model configuration of the dry-steam cycle was designed with the same components used currently in the observed Geothermal Power Plant, consisting of a demister, steam turbine, generator, condenser, gas removal system, and a cooling tower, as shown in Fig. 1. The demister served as a filter to ensure the dryness of steam entering the turbine. This cycle involved a gas removal system, in the form of a liquid ring vacuum pump (LRVP), with a target to produce a turbine power greater than the steam ejector [10].

Furthermore, the condenser used was a direct contact type with higher efficiency and physically smaller when compared with others [17]. Meanwhile, its pressure was assumed at 0.13 bar, which is still in the safe range for operation (0.06–0.15 bars). Conversely, the mechanical induced draft type tower equipment utilized the incoming airflow, assisted by a fan for cooling, and the highest air temperature from the average values in the geothermal power plant area (20°C) was applied in the model to obtain the appropriate cooling tower capacity. There are, however, 13 conditions in the dry-steam cycle, and each level is listed in Table 2. The mass, energy, and exergy balance equations used in the Aspen HYSYS® simulation report are shown in Table 3.

Binary Cycle Modeling

In this model, the binary cycle as shown in Fig. 2, commonly called the Organic Rankine Cycle (ORC), involves the use of Isobutene as its working fluid (i-C₄H₁₀). This was chosen due to its critical temperature, which was lower than the value recorded for excess steam, where the maximum turbine intake pressure is obtained. Furthermore, the operating principle is similar to the Rankine cycle, consisting of fluid compression, liquid phase change into steam, expansion process to produce power, and conversion from steam to liquid, which occurs in a condenser. Therefore, the main equipment of this cycle includes the preheater, evaporator, turbine, condenser, pump, and the recuperator, which was added to utilize the residual steam, observed to possess sufficiently high energy (superheat phase) levels, capable of heating the working fluid before entering the preheater [18]. The mass, energy, and exergy balance equations used in the Aspen HYSYS® simulation report are shown in Table 4.

The initial parameters known as shown in Table 5 are the conditions of geothermal steam (point a), which encompasses the heat exchanger inlet, at a temperature of 160°C, obtained from the exhaust valve, and the heat exchanger (point c), at 70°C and above. This was chosen as the minimum because it is considered safe in instances where silica contained in the fluid has not solidified (the scaling process) [19,20]. The energy conversion occurring in each preheater and evaporator was analyzed using Eqs. (1) and (2) as follows:

$$\dot{m}_b c_b (T_b - T_c) = \dot{m}_{wf} (h_3 - h_2) \quad (1)$$

$$\dot{m}_b c_b (T_a - T_b) = \dot{m}_{wf} (h_4 - h_3) \quad (2)$$

\dot{m}_b and \dot{m}_{wf} represent the mass flow rate of the geothermal and organic working fluids, respectively. T_a is the temperature at which it enters the heat exchanger, which is always known at the initiation of the calculation. Furthermore, ΔT_{pp} was derived from the equipment specifications, illustrating that T_b is known from the value $T_3 + \Delta T_{pp}$.

Kalina Cycle Modeling

The components and principles applied in the Kalina cycle are similar to the binary type, as shown in Fig. 3. However, differences were

Table 1
Parameter data on Kamojang geothermal power plant.

Parameter	Value	Unit	Parameter	Value	Unit
Steam mass flow rate	27	kg/s	Pressure drop demister	0.3	Bar
Pressure	6.5	Bar	Turbine Efficiency	85	%
Temperature	162	°C	Generator Efficiency	95	%
NCG levels (%)	0.5	%	Fan efficiency	70	%
Air temperature	17-20	°C	MCWP efficiency	80	%
Air pressure	0.85	Bar	Pump Efficiency	80	%
Humidity	80	%	Cooling water temperature	27	°C

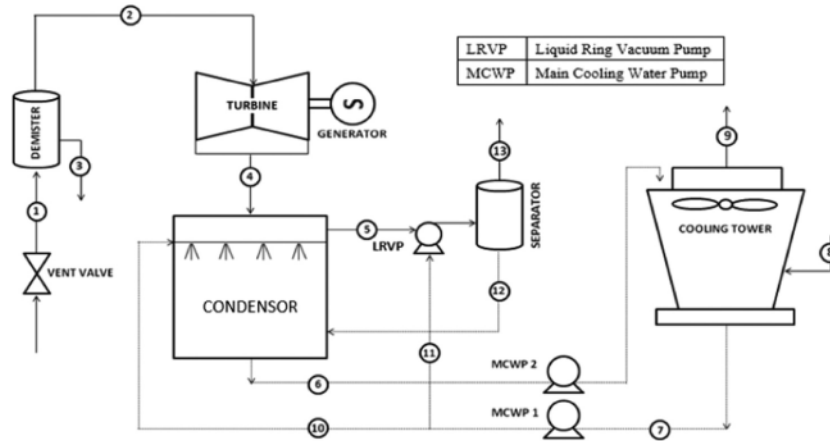

Fig. 1. Schematic diagram of the designed dry-steam cycle.

Table 2
The condition level for each dry-steam cycle.

Condition	Information	ṁ (kg/s)	T (°C)	P (bar)
1	Steam from the vent valve	27	162.13	6.5
2	Saturates steam enters the turbine	26.91	160.26	6.2
3	Discharged brine to blow down	0.09	160.14	6.18
4	Turbine exhaust steam	26.91	51.18	0.13
5	NCG enters LRPV	0.134	51.18	0.13
6	Condensate water of the condenser	627.79	49	2.1
7	Cooling water from the cooling tower	601.1	27	0.85
8	Cooling air enters the cooling tower	506.28	20	0.85
9	Saturated air discharged to environment	506.28	34	0.8512
10	Cooling water enters the condenser	600.71	27	0.85
11	Water enters LRPV	0.3	27	0.85
12	Water from LRPV enters the condenser	0.3	29	0.85
13	The remaining NCG discharged to the environment	0.134	37	0.85

Tab 2.3
The mass, energy, and exergy balance of the dry-steam cycle.

Component	Mass Balance	Energy Balance	Exergy Balance
Demister	$\dot{m}_1 = \dot{m}_2 + \dot{m}_3$	$\dot{m}_1 h_1 = \dot{m}_2 h_2 + \dot{m}_3 h_3$	$\dot{m}_1 e_1 = \dot{m}_2 e_2 + \dot{m}_3 e_3 + I_{Demister}$
Turbine	$\dot{m}_4 = \dot{m}_2$	$\dot{m}_2 h_2 = W_T + \dot{m}_4 h_4$	$\dot{m}_2 e_2 = W_T + \dot{m}_4 e_4 + I_{Turbine}$
Condenser	$\dot{m}_4 + \dot{m}_{10} + \dot{m}_{12} = \dot{m}_5 + \dot{m}_6$	$\dot{m}_4 h_4 + \dot{m}_{10} h_{10} + \dot{m}_{12} h_{12} = \dot{m}_5 h_5 + \dot{m}_6 h_6$	$\dot{m}_4 e_4 + \dot{m}_{10} e_{10} + \dot{m}_{12} e_{12} = \dot{m}_5 e_5 + \dot{m}_6 e_6 + I_{Condenser}$

Tab 2.4
The mass, energy, and exergy balance of the binary cycle.

Component	Mass Balance	Energy Balance	Exergy Balance
Preheater	$\dot{m}_2 = \dot{m}_3, \dot{m}_b = \dot{m}_c$	$\dot{m}_c (h_b - h_c) = \dot{m}_{wf} (h_3 - h_2)$	$\dot{m}_b e_b + \dot{m}_3 e_3 = \dot{m}_c e_c + \dot{m}_2 e_2 + I_{Preheater}$
Evaporator	$\dot{m}_3 = \dot{m}_4, \dot{m}_a = \dot{m}_b$	$\dot{m}_a (h_a - h_b) = \dot{m}_{wf} (h_4 - h_3)$	$\dot{m}_a e_a + \dot{m}_4 e_4 = \dot{m}_b e_b + \dot{m}_3 e_3 + I_{Evaporator}$
Turbine	$\dot{m}_4 = \dot{m}_5$	$\dot{m}_4 h_4 = W_T + \dot{m}_5 h_5$	$\dot{m}_4 e_4 = W_T + \dot{m}_5 e_5 + I_{Turbine}$
Condenser	$\dot{m}_6 = \dot{m}_7, \dot{m}_8 = \dot{m}_9$	$\dot{m}_{wf} (h_6 - h_7) = \dot{m}_9 (h_9 - h_8)$	$\dot{m}_6 e_6 + \dot{m}_9 e_9 = \dot{m}_7 e_7 + \dot{m}_8 e_8 + I_{Condenser}$
Pump	$\dot{m}_7 = \dot{m}_1$	$\dot{m}_1 h_1 = W_P + \dot{m}_7 h_7$	$\dot{m}_1 e_1 = W_P + \dot{m}_7 e_7 - I_{Pump}$
Recuperator	$\dot{m}_5 = \dot{m}_6, \dot{m}_1 = \dot{m}_2$	$\dot{m}_5 h_5 + \dot{m}_1 h_1 = \dot{m}_6 h_6 + \dot{m}_2 h_2$	$\dot{m}_5 e_5 + \dot{m}_1 e_1 = \dot{m}_6 e_6 + \dot{m}_2 e_2 + I_{Recuperator}$

Table 5
The state-level of each binary cycle condition.

Condition	Information	\dot{m} (kg/s)	T (°C)	P (bar)
a	Geothermal fluids enter the evaporator	27	160	6.175
b	Geothermal fluid exits the evaporator	27	160	6.175
c	Geothermal fluid exits the preheater	27	160	6.175
1	Working fluid presses into the recuperator	133.3	46.5	31.48
2	The working fluid enters the preheater	133.3	54	31.48
3	The saturated working fluid enters the evaporator	133.3	125.9	31.48
4	Working fluid saturated steam enters the turbine	133.3	125.9	31.48
5	The working fluid exits the turbine into the recuperator	133.3	60.88	6.33
6	The working fluid enters the condenser	133.3	51.5	6.33
7	The working fluid exits the condenser	133.3	44.56	6.33
8	Cooling water enters the condenser	991.8	27	1.013
9	Cooling water comes out of the condenser	991.8	37	1.013

Table 6
The mass, energy, and exergy balance of the Kalina cycle.

Component	Mass Balance	Energy Balance	Exergy Balance
Evaporator 1	$\dot{m}_2 = \dot{m}_3, \dot{m}_b = \dot{m}_c$	$\dot{m}_g(h_b - h_c) = \dot{m}_{wf}(h_1 - h_2)$	$\dot{m}_b e_b + \dot{m}_1 e_1 = \dot{m}_c e_c + \dot{m}_2 e_2 + I_{Evaporator 1}$
Evaporator 2	$\dot{m}_3 = \dot{m}_4, \dot{m}_a = \dot{m}_b$	$\dot{m}_g(h_a - h_b) = \dot{m}_{wf}(h_2 - h_3)$	$\dot{m}_a e_a + \dot{m}_2 e_2 = \dot{m}_b e_b + \dot{m}_3 e_3 + I_{Evaporator 2}$
Turbine	$\dot{m}_3 = \dot{m}_4$	$\dot{m}_3 h_3 = W_T + \dot{m}_4 h_4$	$\dot{m}_3 e_3 = W_T + \dot{m}_4 e_4 + I_{Turbine}$
Condenser	$\dot{m}_5 = \dot{m}_6, \dot{m}_8 = \dot{m}_9$	$\dot{m}_{wf}(h_5 - h_6) = \dot{m}_{cw}(h_9 - h_8)$	$\dot{m}_5 e_5 + \dot{m}_9 e_9 = \dot{m}_6 e_6 + \dot{m}_8 e_8 + I_{Condenser}$
Pump	$\dot{m}_6 = \dot{m}_7$	$\dot{m}_7 h_7 = W_P + \dot{m}_6 h_6$	$\dot{m}_7 e_7 = W_P + \dot{m}_6 e_6 - I_{Pump}$
Recuperator	$\dot{m}_4 = \dot{m}_5, \dot{m}_1 = \dot{m}_7$	$\dot{m}_4 h_4 + \dot{m}_7 h_7 = \dot{m}_5 h_5 + \dot{m}_1 h_1$	$\dot{m}_4 e_4 + \dot{m}_7 e_7 = \dot{m}_5 e_5 + \dot{m}_1 e_1 + I_{Recuperator}$

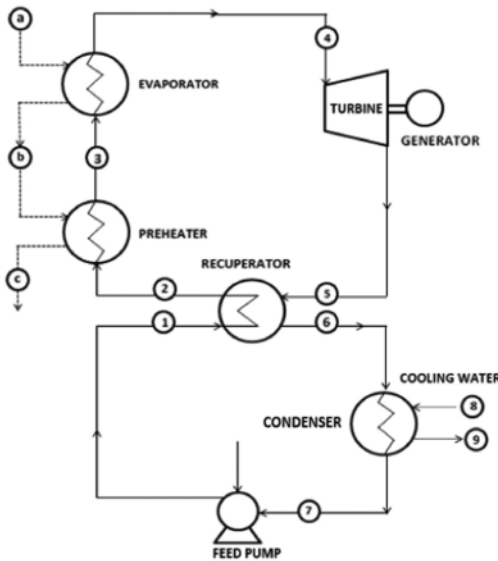

Fig. 2. Schematic diagram of the designed binary cycle.

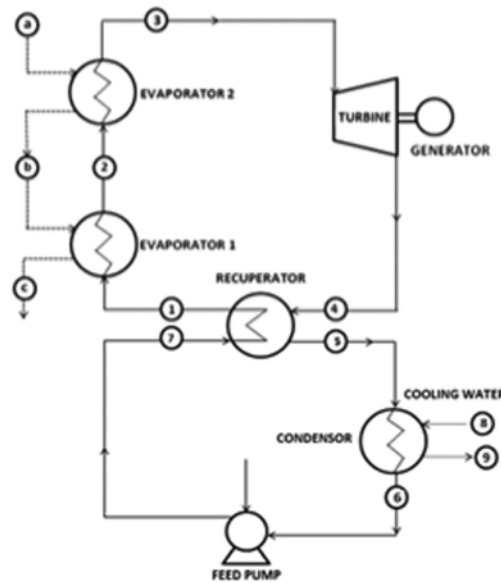

Fig. 3. Schematic diagram of the designed Kalina cycle.

observed in the working fluid used, as it employs a mixture of Ammonia-Water [21], and the fraction was assumed to be 84%. The mass, energy, and exergy balance equations used in the Aspen HYSYS® simulation report are shown in Table 6. After designing the model and computing the data and assumptions, the parameters obtained are presented in Table 7.

Energy and Exergy Analysis

The first step in analyzing energy and exergy was to calculate the enthalpy (h) and entropy (s) in each condition, based on temperature and pressure, using a Computer Aided Thermodynamic Table (CATT) and Reference Fluid Thermodynamic and Transport Properties (REFPROP). Furthermore, during the steam evaluation, non-condensable gas (NCG)

content was taken into account in Eqs. (3) and (4), assuming it consists of 100% CO₂.

$$h_n = h_{s,n}(1 - N) + h_{NCG,n}N \tag{3}$$

$$s_n = s_{s,n}(1 - N) + s_{NCG,2}N \tag{4}$$

Where $h_{s,n}$ declares the enthalpy (kJ/kg) and $s_{s,n}$ illustrates the entropy (kJ/kg.K) of steam, in n condition, whereas $h_{NCG,n}$ and $s_{NCG,2}$ states the enthalpy (kJ/kg) and entropy (kJ/kg. K) of NCG, respectively, and N is a representation of its content on a mass basis [22].

The energy analysis shows the total power, obtained by the calculation of power generated by the turbine, multiplied by its efficiency

Table 7
The state of each condition in the Kalina cycle.

Condition	Information	ṁ (kg/s)	T (°C)	P (bar)
a	Geothermal fluid enters evaporator 2	27	160	6.175
b	Geothermal fluid enters evaporator 1	27	160	6.175
c	Geothermal fluid exits evaporator 1	27	93.02	6.175
1	The working fluid enters the evaporator 1	60	84.05	31
2	The working fluid enters the evaporator 2	60	105.4	31
3	Saturated vapor working fluids enter turbines	60	158.3	31
4	The working fluid exits the turbine into the recuperator	60	109.5	9
5	The working fluid enters the condenser	60	49.01	9
6	The working fluid exits the condenser	60	27.92	9
7	Working fluid presses into the recuperator	60	28.51	31
8	Cooling water enters the condenser	842.5	27	1.013
9	Cooling water comes out of the condenser	842.5	41.39	1.013

Table 8
Recapitulation of power calculations and efficiency of three geothermal power plant.

Cycle	Turbine power (W _t) kW	Generator Power (W _{gen}) kW	Parasitic Load kW	Total power (W _{gen}) kW	Energy Efficiency %	Exergy Efficiency %
Dry-steam	13,529	12,852	332	12,520	16.86	58.95
Kalina	9,438	8,966	1154	7,811	10.49	36.98
Binary	5,310	5,045	1103	3,942	5.3	18.66

and that of the generator, which was further reduced by parasitic load or the power consumed by the supporting components, as shown in Eq. (5) follows:

$$W_{total} = [\dot{m} (h_{out,turbine} - h_{in,turbine}) \times \eta_{turbine} \times \eta_{generator}] - W_{parasitic\ load} \tag{5}$$

In calculating the exergy analysis, its balance was carried out in Eq. (4), stating that a change equivalent to the total, is transferred through the system boundary and that which was destroyed in the unit due to their irreversibility [23]. \dot{E} described the exergy flow (kJ) as shown in Eq. (6), while e described the specific exergy (kJ/kg) obtained by Eq. (7).

$$\begin{aligned} <ct> \dot{E} <ot>_{in} - <ct> \dot{E} <ot>_{out} \\ - <ct> \dot{E} <ot>_{destroyed} = \Delta <ct> \dot{E} <ot>_{sistem} \end{aligned} \tag{6}$$

$$e = h_1 - h_0 - T_0 (s_1 - s_0) \tag{7}$$

The exergy destruction $<ct> \dot{E} <ot>_D$ in the components can be compared with its rate in the whole system $<ct> \dot{E} <ot>_{in,tot}$, this comparison is called as destruction ratio y_D in Eq. (8):

$$y_D = \frac{<ct> \dot{E} <ot>_D}{<ct> \dot{E} <ot>_{in,tot}} \tag{8}$$

The exergetic efficiency is defined as the ratio between the quantities of an exergy product, based on the balance in the rate of a system, as stated in Eq. (9):

$$\eta = \frac{\sum_{out} <ct> \dot{E} <ot>}{\sum_{in} <ct> \dot{E} <ot>} \tag{9}$$

Results and Discussion

Based on the data obtained, the net power (W_{net}) can be calculated from each cycle of the turbine power and parasitic load originating from the supporting components of a generator. Meanwhile, the efficiency of the vent steam was obtained through the comparison of W_{net} with the energy and exergy value, as seen in Table 8.

Table 8 shows that the dry-steam cycle could convert the highest energy among the three sequences designed. In this case, excess steam

Table 9
The composition of parasitic load for each cycle.

Parasitic load	Dry-steam Cycle	Binary Cycle	Kalina Cycle
Pump Power	0 kW	731.48 kW	795 kW
MCWP Power	206 kW	208.78 kW	193.88 kW
LRVP power	39.05 kW	0 kW	0 kW
Fan Power	123 kW	114 kW	116 kW

enters the cycle through the demister component, which is then directly used to turn the turbine. With the turbine output condition set to vacuum, it is possible to obtain a large specific enthalpy and exergy difference in the turbine and produce high power. Furthermore, this high turbine power was caused by a simpler design with minimal exergy elimination and reduced parasitic load, comparatively, as listed in Table 9.

A comparison with the current dry-steam cycle at the existing Geothermal Power Plant showed the energy efficiency designed to have the same level, within the range of 16-17%, and the venting process of steam was attributed to low efficiency. Hence, the steam supplied is incapable of being fully utilized due to the fluctuations in pressure and excess steam occurring. In addition, the dry vapor series involved implementing as many zero venting systems as possible. Regarding parasitic load, the dry-steam cycle only consumes 332 kW or 2.65% of the power generated. This value is very different from the other two cycles because the dry-steam cycle does not require a feed pump or pump to increase the working fluid pressure until it reaches the desired Turbine Inlet Pressure as in the binary and Kalina cycles.

Table 10 describes the amount of exergy that enters, leaves, and is destroyed in the dry-steam cycle component. After passing through the demister component, dry-steam enters the turbine with an exergy of 20,987.51 kW. It undergoes an expansion process with two outputs in the form of a turbine power of 13,529 kW and the remaining steam to be condensed at 5635 kW. The turbines are the elements with the highest exergy destruction in this sequence as they are influenced by the design and construction, including flow transitions between levels, leakage around the blade tip and seal, and the final blade length. In addition, the pressure in the condenser component (vacuum) enhanced the likelihood of outside air leakages due to the presence of cracks in the expansion joint, which is estimated to increase the condenser load.

The red line in Fig. 4 describes an inverse correlation between the pressure of the condenser and turbine power. An increase in pressure

Table 10
Calculation results of dry-steam cycle exergy.

Component	Exergy enter kW	Exergy out kW	Exergy wasted kW	Irreversibility kW	Irreversibility ratio %
Demister	21239.82	20987.51	10.03	242.28	1.14
Turbine	20987.51	18957.61		2029.90	9.67
Condenser	5635.01	3624.82		2010.19	35.67

Table 11
Calculation results of binary cycles exergy.

Component	Exergy enter kW	Exergy out kW	Exergy wasted kW	Irreversibility kW	Irreversibility ratio %
Evaporator	35120.46	34003.97		1116.49	3.18
Preheater	23628.83	13999.17	5966.02	4033.64	17.07
Turbine	18384.74	10977.39		2096.676	11.40
Condenser	11061.01	7186.203	1984.889	1889.918	17.09
Pump	8332.183	7186.203		1145.98	13.75
Recuperator	18724.38	18713.05		11,3305	0.06

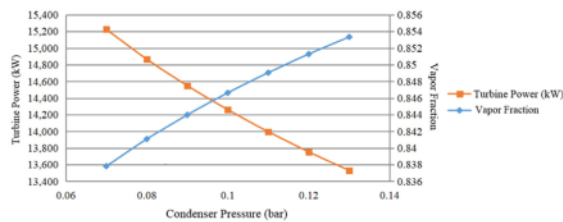

Fig. 4. Effect of condenser pressure on turbine power.

in a specific state will cause an increase in the enthalpy and entropy values of these conditions so that the difference between the exergy entering and leaving the turbine components will be smaller and reduce the turbine power. However, the blue line illustrates the vapor fraction of steam in the varied condenser pressure, which indicates an entirely different tendency, as the decline further reduced the steam output of the turbine. However, it does not directly impact the power produced. A lower mass fraction of the vapor is related to the elevation in the liquid phase at the output, which further causes erosion within, after the cycle operates for a long time. In this case, the possible condenser pressure under actual conditions and following environmental conditions at the Kamojang geothermal power plant ranges from 0.1 to 0.13 bar. Based on these several possibilities, the optimal condition was chosen, which produces the highest turbine power and a fairly high steam fraction in the achievable range, namely at 0.1 bar condenser pressure, producing a net power of 13,160 kW.

In the binary cycle, the exergy that enters the evaporator component is 35,120 kW which comes from excess steam exergy of 21,121 kW, and exergy of Isobutane, which has been preheated by the preheater until it reaches a saturated liquid state of 13,999 kW. In the evaporator, Isobutane does not increase in temperature. It changes in phase from liquid to saturated vapor and produces an exergy annihilation value of about 1116.49 kW. The exergy of the geothermal steam coming out of the evaporator is then used for preheating the Isobutane in the preheater from a temperature of 54°C to 125.9°C. The irreversibility in the preheater components was highest among other components, as shown in Table 11. This is probably caused by several reasons, including the variation in temperature between the hot and cold fluid, the friction observed during a pass through the tube, and heat dissipation to the environment. In terms of the amount of power produced, the binary cycle is far behind the dry-steam variety. Therefore, several steps are taken to optimize the cycle, including variations in the turbine inlet pressure (TIP), with the results plotted in Fig. 5.

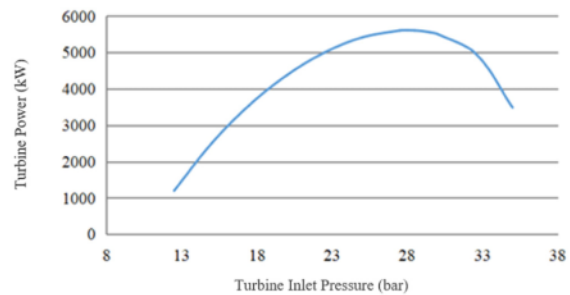

Fig. 5. Relationship between turbine inlet pressure (TIP) and turbine power.

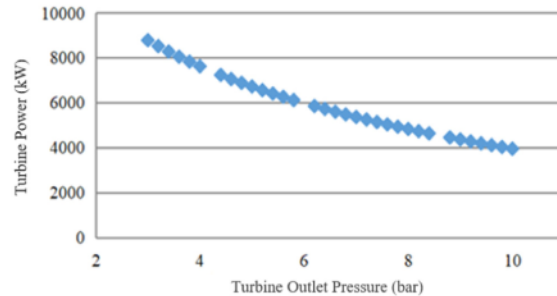

Fig. 6. Relationship between turbine exit pressure and turbine power.

In Fig. 5, an increase in turbine power was observed in the TIP, from 13 to 31 bars, which became smaller through the exhibition of a decreasing line. This can, however, be analyzed from the properties of Isobutane enthalpy and entropy that are unstable near the critical pressure. Hence, the optimal TIP was obtained as 31 bars.

Conversely, optimization is also conducted with variations in the exhaust turbine, known to have a fairly large exergy of 10,977.39 kW. This was carried out by varying the output pressure in the ranges of 3–10 bars, indicating that a reduced value correlates with an elevation in power produced as shown in Fig. 6.

In the Kalina cycle, the turbine is a component with the largest exergy destruction value of 2769.6 kW, as shown in Table 12. Therefore, the system needs to be optimized based on parameters with greater influence, including ammonia mass fraction, TIP, and turbine exit pressure to obtain the maximum output power and efficiency.

Table 12
Calculation results of Kalina cycle exergy.

Component	Exergy enter kW	Exergy out kW	Exergy wasted kW	Irreversibility Kw	Irreversibility ratio %
Evaporator 1	78955.89	77023.83		1932.06	2.44
Evaporator 2	61239.63	57834.6	899.37	2505.66	4.09
Turbine	69078	56870.4		2769.6	4.01
Condenser	49927.92	47244.6	2636.27	47.0545	0.094
Pump	48247.8	47244.6		1003.2	2.08
Recuperator	104323.2	102918		1405.2	1.35

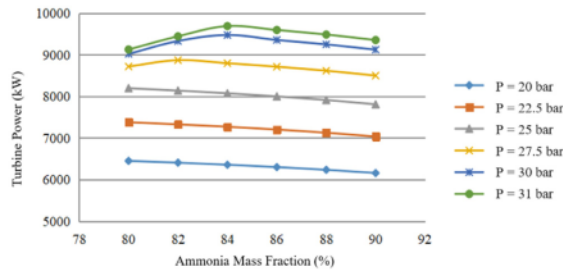

Fig. 7. Effect of ammonia mass fraction and TIP on turbine power.

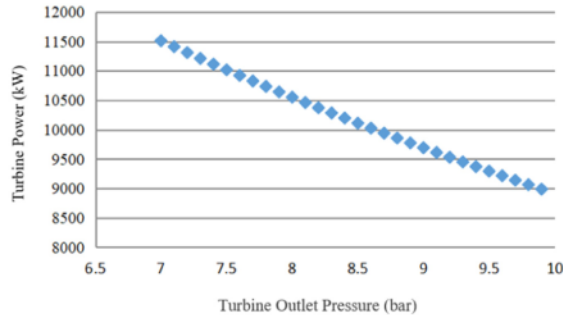

Fig. 8. Relationship between turbine exit pressure and turbine power.

Fig. 7 shows the effect of ammonia mass fractions, taken at intervals between 80–90% and TIP, on a scale of 20–31 bars on the turbine power. However, the difference in the amount contained in the mixture affects the temperature and the entropy value produced. Therefore, based on the graph, it can be concluded that the most optimal conditions, with the greatest yield, were observed at 31 bars, with an 84% mass fraction of ammonia.

The optimization of turbine exit pressure was in the range of 7–9.9 bars [19]. Hence, utilizing a 31 bar TIP and 84% ammonia mass fraction, the highest power was observed as 11,510 kW at the 7 bar exit pressure, as seen in Fig. 8. This increase in power will be followed by an increase in energy efficiency and generator exergy efficiency.

Optimization has been carried out from the three geothermal power plant cycles by varying parameters hypothesized to affect turbine power significantly. The results of the optimization are then summarized in Table 13.

Economic Analysis

In determining electricity production/LEGC prices from a generator, identifying component sizing as a basis for establishing the cost of spare parts is the first step conducted. However, due to the limitations of related detailed information, the values were obtained through some literature involving a component capacity scale approach [24].

Table 13
Summary of the results of optimization carried out in each cycle.

Cycle		Before Optimization	After Optimization
Dry-steam	Wt	13,529 kW	Wt 14,260 kW
	Wett	12,512 kW	Wett 13,160 kW
	Efficiency I	16.86%	Efficiency I 17.98%
Binary	Efficiency II	58.95%	Efficiency II 62.83%
	Wt	5310 kW	Wt 8274 kW
	Wett	3942 kW	Wett 7170 kW
Kalina	Efficiency I	5.3%	Efficiency I 9.63%
	Efficiency II	18.66%	Efficiency II 33.91%
	Wt	9438 kW	Wt 11,510 kW
	Wett	7811 kW	Wett 10,355 kW
	Efficiency I	10.49%	Efficiency I 13.91%
	Efficiency II	36.98%	Efficiency II 49.03%

Table 14
Component sizing for each cycle.

Type of Cycle	Component	Information	Value
Dry-steam Cycle	Demister	Diameter	1.76 m
	Turbine	Power	13,160 kW
	MCWP	Power	186.4 kW
	LRVP	Capacity of NCG	150.36 cfm
	Cooling tower	Air capacity	13,800 GPM
Binary Cycle	Condenser	Surface area	5,832 m ²
	Evaporator	Surface area	267 m ²
	Preheater	Surface area	513 m ²
	Recuperator	Surface area	447 m ²
	Condenser	Surface area	3,317 m ²
	Turbine	Power	8,274 kW
	Pump	Power	731 kW
Kalina Cycle	MCWP	Power	208 kW
	Cooling tower	Air capacity	15,895 GPM
	Evaporator 1	Surface area	1613 m ²
	Evaporator 2	Surface area	717 m ²
	Recuperator	Surface area	1583 m ²
	Condenser	Surface area	6995 m ²
	Turbine	Power	11,510 kW
Pump	Power	795 kW	
	MCWP	Power	193 kW
	Cooling tower	Air capacity	13,311 GPM

Component Sizing

The component capacity determination was interpreted into several parameters according to its type, e.g., the heat exchanger. Furthermore, the value of the heat transfer surface area (A) is needed, which is known by the Log Mean Temperature Difference (LMTD) method. However, pumps and turbines require a capacity or power value [25], and the cooling tower component obliges the air capacity (calculation of cooling tower refers to the rule of thumb in wet cooling tower design [26], and the demister uses the Souders-Brown equation. Hence, the results of component sizing calculations are summarized in Table 14.

Table 15
The results of calculating the total capital and investment in the dry-steam cycle.

I. Fixed capital investment		
A. Direct Cost		
1	Onsite Costs	
	Purchased Equipment Cost	
	Cost	
-	Demister	19201
-	Turbine	4330934
-	Condenser	730367
-	Liquid Ring Vacuum Pump	9335
-	MCWP	65772
-	Cooling Tower	343872
	Total purchased-equipment cost (PEC)	5155611
	Piping (10% of PEC)	515561
	Total Onsite Cost	5671172
2	Offsite Cost	
	Land	0
	Total offsite cost	0
	Total Direct Cost	5671172
B. Indirect Cost		
	Engineering + supervision (8% of DC)	453693
	Construction cost (15% DC)	850675
	Contingency (20% of above the sum)	260873
	Total Indirect Cost	1565243
	Fixed Capital Investment (FCI)	7236416
II. Other Outlays		
A.	Start-Up	125328
B.	Working capital	47288
C.	Cost of licensing, research, and development	1974000
D.	Allowance for funds used during construction	88537
	Total other outlays	3035154
	Total capital investment	10271570 US \$

Purchased Equipment Cost

Based on the results of component sizing, it is possible to estimate purchased equipment cost (PEC) from the heat exchanger components using Eq. (10), while the power was assessed using Eq. (11) in Dorj [27]. Meanwhile, the demister and cooling tower components used the ratio method, based on the graph obtained from the chemical process design [22].

$$C_{equipment} = C_0 \cdot (\text{size_of_equipment})^n \tag{10}$$

$$C_{equipment} = C_0 \cdot (\text{power_capacity})^n \tag{11}$$

Total Capital Investment

The calculation of total capital investment (TCI) uses several assumptions and methods, obtained in Dorj [27], with the results shown in Table 15, Table 16, and Table 17.

After identifying the TCI value, as well as the operating and maintenance costs from each cycle, the price of electricity production (cents/kWh) was then determined, considering economic conditions such as the fiscal age of the plant (30 years) used in Indonesia, and a Discount rate of 10%. Furthermore, the results of the LEGC were listed in Table 18, using Eq. (12) and assuming the rupiah exchange rate against the US dollar is Rp. 14,000/US \$.

$$LEGC = \frac{\sum_{t=1}^n \left(\frac{I_t + M_t + F_t}{(1+r)^t} \right)^{-1}}{E \sum_{t=1}^n \frac{E_t}{(1+r)^t}} \tag{12}$$

LEGC is the cost of production per kWh (US \$/kWh), I_t is the total investment expenditure per year, M_t is the annual operation and maintenance cost, F_t depicts fuel costs, E_t is the amount of electricity generated yearly, r is the discount rate, and n is the age of the generator [28].

Table 16
The results of calculating the total binary cycle capital investment.

I. Fixed capital investment		
A. Direct Cost		
1	Onsite Costs	
	Purchased Equipment Cost	
	Cost	
-	Evaporator	66222
-	Preheater	111465
-	Recuperator	197739
-	Condenser	495502
-	Turbine	3129704
-	Pump (feed pump + MCWP)	332214
-	Cooling Tower	291520
	Total Purchased-equipment cost (PEC)	4332848
	Piping (10% of PEC)	4332848
	Total Onsite Cost	4766133
2	Offsite Cost	
	Land	0
	Total offsite cost	0
	Total Direct Cost	4766133
B. Indirect Cost		
	Engineering + supervision (8% of DC)	381290
	Construction cost (15% DC)	714920
	Contingency (20% of above the sum)	219242
	Total Indirect Cost	1315452
	Fixed Capital Investment (FCI)	6081586
II. Other Outlays		
A.	Start-Up	107857
B.	Working capital	47288
C.	Cost of licensing, research, and development	1241100
D.	Allowance for funds used during construction	328862
	Total other outlays	1725107
	Total capital investment	7806694 US \$

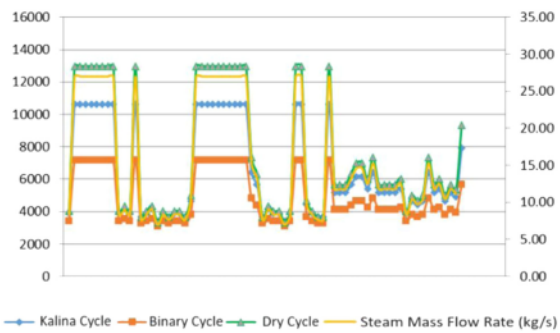

Fig. 9. The effect of steam mass flow to the turbine power.

Performance Analysis

The power plant performance is expressed by the value of the Capacity Factor (CF), which is the ratio between the actual power produced in a given period with the maximum output power of its design capacity. The value of CF is very dependent on steam mass flow (as a fuel) and the power plant design. Considering that the energy pairs or the steam used in the three cycles are the same, which has changed every time, it is necessary to analyze the effect of steam fluctuation on the output power of the three types of geothermal power plant cycles with the results described in Fig. 9.

Based on the graph obtained from the simulation of three types of geothermal power plant cycles for three days, it can be seen that the three cycles experienced fluctuations in turbine power which were influenced by changes in the mass flow rate of steam. In the dry-steam cycle design, it is due to the direct use of steam to turn the turbine. As for the binary cycle and the Kalina cycle, steam is used to heat the working fluid Isobutane or the Ammonia-Air mixture through a heat exchanger, which has a fixed capacity with a pinch point according to

Table 17
The calculated results of the total capital investment of the Kalina cycle.

I. Fixed capital investment		
A. Direct Cost		
1	Onsite Costs	
	Purchased Equipment Cost	
-	Evaporator 1	278421
-	Evaporator 2	145662
-	Recuperator	274317
-	Condenser	900307
-	Turbine	3066893
-	Pump	349371
-	Cooling Tower	342280
	Total Purchased-equipment cost (PEC)	5357255
	Piping (10% of PEC)	535725
	Total Onsite Cost	5892980
2	Offsite Cost	
	Land	0
	Total offsite cost	0
	Total Direct Cost	5892980
B. Indirect Cost		
	Engineering + supervision (8% of DC)	471438
	Construction cost (15% DC)	883947
	Contingency (20% of above the sum)	271077
	Total Indirect Cost	1626462
	Fixed Capital Investment (FCI)	7519443
II. Other Outlays		
A.	Start-Up	155110
B.	Working capital	47288
A.	Cost of licensing, research, and development	1726500
B.	Allowance for funds used during construction	598583
	Total other outlays	2325083
	Total capital investment	9844526 US \$

Table 18
Prices for electricity production from three geothermal power plant cycles.

Geothermal Power Plant	Levelized Electricity Generating Cost (LEGC)	
Dry-steam Cycle	7.48 € US \$/kWh	IDR 1048/kWh
Kalina Cycle	9.30 € US \$/kWh	IDR 1303/kWh
Binary Cycle	11.51 € US \$/kWh	IDR 1612/kWh

Table 19
Capacity factor (CF) of three different cycle.

Cycle	Dry-Steam	Binary	Kalina
Capacity Factor	57,07%	67,33%	60,79%

the initial design conditions. In both cycles, the power generated also follows the mass flow rate of the steam supply in the heat exchanger because the smaller the steam mass flow rate, the lower the temperature reached by the working fluid to rotate the turbine.

Geothermal power plants generally serve as a base load, hence the need to design a new geothermal power plant cycle for a constant operation to attain maximum capacity. The power plant performance is then represented by the CF value, which is also considered in subsequent economic analyses. The Capacity Factor value can be calculated using the Eq. (13) with the result in Table 19.

$$CF = \frac{\text{Total amount of energy produced during period of time}}{\text{Amount energy produced at full capacity}} \quad (13)$$

Environment Impact Analysis

As a form of renewable energy, geothermal is a potential environmental pollutant obtained from substances within the earth and mobilized by steam to the surface, despite the smaller percentage. Steam from geothermal fields contains non-condensable gas dominated by CO₂ of 95–98% and H₂S of 2-3%.

Table 20
The emissions of CO₂ and H₂S in three cycles.

Cycle	CapacityEmissions (gr/kWh)		
	(MW)	CO ₂	H ₂ S
Dry-Steam	13.4	34.64	0.069
Binary	6.7	0	0
Kalina	9.94	0	0

Calculations of CO₂ and H₂S emissions used in this study adopted the method of K.K. Bloomfield and J.N Moore in Yuniarto [29]. With an estimated NCG content in geothermal steam of 0.5% consisting of 99.8% CO₂ and H₂S of 2%, the results of the calculation of emissions released for each cycle can be seen in Table 20.

The gas removal system at dry-steam cycle possibly released 8.088,98 Ton/year of CO₂ and 16,18 Ton/years H₂S to the atmosphere where the other system, binary and Kalina cycle, bring the gas for reinjection system to the earth. This is due to the dry-steam cycle technology, the steam that has been used to rotate the turbine and then enters the condenser still contains NCG, which is then sucked in by the LRVP. In the LRVP, NCG mixes with the service liquid and will be separated by a separator where the NCG is discharged directly into the air while the service liquid returns to the condenser.

Global warming is a current concern for most countries, including Indonesia. Indonesia is committed to reducing emissions by 29% (834 million tons of CO₂) by 2030. Thus, a special policy is needed to control the amount of carbon emissions in the atmosphere and to serve as an incentive approach in the form of a special levy, e.g., a tax, imposed by the government for every ton of CO₂ emission released.

Many countries in the world have implemented this policy which is commonly referred to as Carbon Tax. Taxes imposed by the government will motivate industry/emitters to reduce CO₂ emissions if the costs they incur are less than having to pay enormous taxes each year. Several countries in Europe and Australia have implemented a carbon tax of 20 US\$/ton of CO₂. If the carbon tax scenario is applied in Indonesia, with emissions emitted by the dry-steam cycle of 8088.98 tons, the tax to be paid will be 161,780 US\$/year or more than Rp 2.26 billion/year.

Assessment and Comparison of Three Different cycles

Various analyses have been carried out on the three designed cycles: thermodynamics, plant performance, economic, and environmental impact. In this section, an assessment will be conducted with parameters including energy efficiency, exergy efficiency, exergy destruction, capacity factor (CF), capital costs, generated electricity costs, and environmental impacts, summarized in Table 21.

In terms of the generator's thermodynamic efficiency and the generator economics, the dry-steam cycle is superior to the other two cycles. Still, it has a weakness in the performance of the generator, namely the value of the capacity factor due to large power fluctuations. In addition, this cycle is also the only cycle that has an environmental impact by emitting CO₂ and H₂S emissions.

While the Kalina cycle is the second option in selecting the right cycle for the utilization of excess steam, the use of ammonia as a working fluid is currently avoided due to its high toxicity. In addition, this cycle also does not have any environmental impact similar to the binary cycle. While the binary cycle has a weakness in cycle efficiency, the capacity factor value is the best among the other two cycles even though its application is less profitable from an economic point of view due to expensive component prices and low power generated.

Conclusion

Based on the data and analysis conducted in this study, conclusions can be drawn as described below:

Table 21
Assessment of three geothermal cycles from some parameters.

Quality	Energy and Exergy Efficiencies	Exergy Destruction	Capacity Factor	Capital Cost	LEGC	Environmental Impact
3	Dry-Steam	Dry-Steam	Binary	Dry-Steam	Dry-Steam	Binary
2	Kalina	Kalina	Kalina	Kalina	Kalina	Kalina
1	Binary	Binary	Dry-Steam	Binary	Binary	Dry-Steam
Geothermal Cycles	Dry-Steam Cycle	Binary Cycle	Kalina Cycle			
Value	15	10	13			

- The thermodynamic analysis was carried out in three different cycles. The dry-steam cycle generates total power (W_{net}) of 12,520 kW, while the energy and exergy efficiency reached 16.86% and 58.95%, respectively, with the turbine as the largest source of irreversibility at 2029 kW. Kalina cycle generates less power of 7.811 kW, with energy and exergy efficiency of 10.49% and 36.98%, respectively. Turbine and evaporator 2 are the main sources of exergy destruction. The binary cycle produces the smallest power of 3942 kW, while its energy and exergy efficiencies reached 5.3% and 18.66%, respectively. The preheater is the component with the largest irreversibility, by 4033 kW.
- Optimization was conducted to elevate the total power obtained. Meanwhile, lower condenser pressure indicates the possible production of higher turbine power using the dry-steam cycle. However, this was carried out in the binary variety with variations in the turbine inlet and exit pressure, with the ideal conditions of 31 and 3.4 bars. Furthermore, the optimization results showed an increase in the total power of 7170 kW while in the Kalina cycle. This was carried out by varying the concentration of Ammonia-Water, which increased turbine power by 24%.
- The economic analysis was conducted by calculating each cycle's total capital cost (TCC) and Levelized Electricity Generating Cost (LEGC). Therefore, the construction of a geothermal power plant with a dry-steam cycle requires an investment value of 10,271,570 US \$, while that of binary and Kalina cycles were 7,806,694 US \$ and 9,844,526 US \$, respectively. Furthermore, the lowest production price observed in the dry-steam version was 7.48 ¢ US \$/kWh, while the others were 9.30 ¢ US \$/kWh and 11.51 ¢ US \$/kWh, respectively.
- The performance of each cycle is evaluated by the value of capacity factor (CF) with the results of the Kalina cycle of 60.79%, the binary cycle of 67.33%, and the dry-steam cycle of 57.07%
- Environmental analysis is done by evaluating CO₂ and H₂S emissions released into the air. The dry-steam cycle releases 34.64 g/kWh CO₂ and 0.069 g/kWh H₂S into the air, while the other two cycles produce zero emissions.
- The results showed the advantages of the dry-steam cycle, both in terms of energy efficiency and plant economics. Whereas the Kalina cycle and binary cycle have the advantage of minimum environmental impact by not releasing emissions into the air.

Data availability

Visible in ALL reading formats

Declaration of Competing Interest

The authors declare that they have no known competing financial interests or personal relationships that could have appeared to influence the work reported in this paper.

Acknowledgment

This research was supported by Indonesia Endowment Fund for Education (LPPD), the Indonesian Ministry of Finance. We thank our col-

leagues from PT. Indonesia Power UPJP Kamojang who provided insight and expertise that greatly assisted the research.

References

- [1] B. Rudiyanto, M. Aries, N. Agung, W. Widjonarko, M. Hijriawan, An update of second law analysis and optimization of a single-flash geothermal power plant in Dieng, Indonesia, *Geothermics* 96 (March) (2021) 102212, doi:10.1016/j.geothermics.2021.102212.
- [2] E. Assareh, M. Delpisheh, E. Farhadi, W. Peng, H. Moghadasi, Optimization of geothermal- and solar-driven clean electricity and hydrogen production multi-generation systems to address the energy nexus, *Energy Nexus* 5 (November 2021) (2022) 100043, doi:10.1016/j.nexus.2022.100043.
- [3] F. Bilgili, S. Kuşkaya, P. Gençoğlu, Y. Kassouri, A.P.M. Garang, The co-movements between geothermal energy usage and CO₂ emissions through high and low frequency cycles, *Environ. Sci. Pollut. Res.* 28 (45) (2021) 63723–63738, doi:10.1007/s11356-020-11000-x.
- [4] M. El Haj Assad, E. Bani-Hani, M. Khalil, Performance of geothermal power plants (single, dual, and binary) to compensate for LHC-CERN power consumption: comparative study, *Geotherm. Energy* 5 (1) (2017) 1–16, doi:10.1186/s40517-017-0074-z.
- [5] E.E. Michaelides, Future directions and cycles for electricity production from geothermal resources, *Energy Convers. Manag.* 107 (2016) 186–192, doi:10.1016/j.enconman.2015.07.057.
- [6] R. Bertani, Geothermal power generation in the world 2010–2014 update report, *Geothermics* 60 (2016) 31–43, doi:10.1016/j.geothermics.2015.11.003.
- [7] R. DiPippo, *Geothermal Power Plants*, 2nd ed., Butterworth-Heinemann, Oxford, 2008, doi:10.1016/B978-0-7506-8620-4.X5001-1.
- [8] T. Abbas, A. Ahmed Bazmi, A. Waheed Bhutto, G. Zahedi, Greener energy: issues and challenges for Pakistan-geothermal energy prospective, *Renew. Sustain. Energy Rev.* 31 (2014) 258–269, doi:10.1016/j.rser.2013.11.043.
- [9] R. Adiprana, *Evaluation and Optimization of Kamojang Unit 1-2-3 PLTP Based on Exergy Analysis*, Institut Teknologi Bandung, 2014.
- [10] L.A. Prananto, T.M. Fauzi Soelaiman, M. Aziz, Utilization of excess steam through dry steam cycle at Kamojang geothermal power plant, *Energy Procedia* 142 (2017) 160–165, doi:10.1016/j.egypro.2017.12.026.
- [11] S. Suryadarma, T. Dwikorianto, A.A. Zuhro, A. Yani, Sustainable development of the Kamojang geothermal field, *Geothermics* 39 (4) (2010) 391–399, doi:10.1016/j.geothermics.2010.09.006.
- [12] I.A. Pratama, "Design and simulation of the kalina cycle operational system capacity of 50 ton/hour using gas from the vent valve Kamojang PLTP system," Institut Teknologi Sepuluh Nopember, 2017.
- [13] N.A. Pambudi, R. Itoi, S. Jalilinasrabad, K. Jaelani, Exergy analysis and optimization of Dieng single-Flash geothermal power plant, *Energy Convers. Manag.* 78 (2014) 405–411, doi:10.1016/j.enconman.2013.10.073.
- [14] R. Adiprana, S. Purnomo, I.E. Lubis, Kamojang Geothermal Power Plant Unit 1-2-3 Evaluation and Optimization Based on Exergy Analysis, *Proc. World Geotherm. Congr. (April)* (2015) 19–25.
- [15] N. Nasruddin, I. Dwi Saputra, T. Mentari, A. Bardow, O. Marcelina, S. Berlin, Exergy, exergoeconomic, and exergoenvironmental optimization of the geothermal binary cycle power plant at Ampallas, West Sulawesi, Indonesia, *Therm. Sci. Eng. Prog.* 19 (June) (2020) 100625, doi:10.1016/j.tsep.2020.100625.
- [16] M.H. Seyyedvalilu, V. Zare, F. Mohammadkhani, Comparative thermo-economic analysis of trigeneration systems based on absorption heat transformers for utilizing low-temperature geothermal energy, *Energy* 224 (2021) 120175, doi:10.1016/j.energy.2021.120175.
- [17] D. Bharatan, E. Hoo, D. Paul, An assessment of the use of direct contact condensers with wet cooling systems for utility steam power plants, United States (1992) [Online] Available, doi:10.1016/B978-1-4160-4389-8.50098-4.
- [18] R. DiPippo, *Geothermal Power Plants: Principles, Applications, Case Studies and Environmental Impact*, 4th ed., Elsevier Ltd., United Kingdom, 2015, doi:10.1016/C2014-0-02885-7.
- [19] N. Laksmingpuri, A. Martinus, Study of the content and temperature of geothermal gas Kamojang with a grid diagram, *J. Beta Gamma Isot. Radiat. Appl.* 4 (2) (2013) 69–79.
- [20] N.A. Pambudi, R. Itoi, S. Jalilinasrabad, K. Jaelani, Performance improvement of single-flash geothermal power plant applying three cases development scenarios using thermodynamic methods performance improvement of single-flash geothermal power plant applying three cases development scenarios using thermodyn, in: *Proceedings of the World Geothermal Congress Melbourne, Aust.*, 2015 19–25 April 2015.
- [21] A.I. Kalina, H.M. Leibowitz, Application of the Kalina cycle technology to the geothermal power generation, *Geotherm. Resour. Counc. Trans.* 13 (1989) 35–38.

- [22] R. Adiprana, D.S. Purnomo, I.E. Lubis, Kamojang geothermal power plant unit 1-2-3 evaluation and optimization based on exergy analysis, in: Proceedings of the World Geothermal Congress Melbourne, Aust, 2015 19-25 April 2015.
- [23] A. Bejan, G. Tsatsaronis, M. Moran, Thermal Design and Optimization, John Wiley & Sons, Inc, New York, 1996.
- [24] H.P. Loh, J. Lyons, and C.W. White, "Process equipment cost estimation final report," United States, 2002. doi: 10.2172/797810.
- [25] A. Mereto, M.S. Guðjónsdóttir, V. Chauhan, Thermoeconomic Analysis of Geothermal Power Cycles for IDDP-1 Chloride Mitigation, Reykjavik University, 2016.
- [26] S. Leeper, "Wet cooling towers: rule-of-thumb design and simulation," United States, 1981. doi:10.2172/5281927.
- [27] P. Dorj, Thermoeconomic Analysis of a New Geothermal Utilization CHP Plant, University of Iceland, 2005.
- [28] U.S. Department of Energy Office of Indian Energy Policy and Programs Levelized Cost of Energy (LCOE), United States, 2015 [Online]. Available: <https://www.energy.gov/sites/prod/files/2015/08/f25/LCOE.pdf> .
- [29] Yuniarto, T.E.B. Soesilo, E. Heviati, Geothermal power plant development in Indonesia, in: Proceedings of the World Geothermal Congress, 2015, pp. 1–5.

Utilization of Excess Steam from a Vent Valve in a Geothermal Power Plant

ORIGINALITY REPORT

8%

SIMILARITY INDEX

8%

INTERNET SOURCES

4%

PUBLICATIONS

4%

STUDENT PAPERS

PRIMARY SOURCES

1

www.researchgate.net

Internet Source

3%

2

catalog.lib.kyushu-u.ac.jp

Internet Source

1%

3

Submitted to Universiti Malaysia Perlis

Student Paper

1%

4

Lukman Adi Prananto, Tubagus Muhammad Fauzi Soelaiman, Muhammad Aziz. "Utilization of excess steam through dry steam cycle at Kamojang geothermal power plant", Energy Procedia, 2017

Publication

1%

5

Lukman Adi Prananto, Gea Fardias Mu'min, Tubagus Muhammad Fauzi Soelaiman, Muhammad Aziz. "Dry steam cycle optimization for the utilization of excess steam at Kamojang geothermal power plant", AIP Publishing, 2018

Publication

1%

6	uhra.herts.ac.uk Internet Source	1 %
7	link.springer.com Internet Source	1 %
8	mafiadoc.com Internet Source	1 %
9	tuprints.ulb.tu-darmstadt.de Internet Source	1 %

Exclude quotes On

Exclude matches < 1%

Exclude bibliography On