

# MODELLING AND SIMULATION OF INDUSTRIAL HEAT EXCHANGER NETWORKS UNDER FOULING CONDITION USING INTEGRATED NEURAL NETWORK AND HYSYS

*by Titik Budiati*

---

**Submission date:** 21-Feb-2023 11:16AM (UTC+0700)

**Submission ID:** 2019345261

**File name:** Paper\_12.0\_Kursor.docx (744.42K)

**Word count:** 2483

**Character count:** 13747

**MODELLING AND SIMULATION OF INDUSTRIAL HEAT EXCHANGER NETWORKS UNDER FOULING CONDITION USING INTEGRATED NEURAL NETWORK AND HYSYS**

**<sup>a</sup>Totok R. Biyanto, <sup>b</sup>Roekmono, <sup>c</sup>Andi Rahmadiansyah, <sup>d</sup>Aulia Siti Aisyah, Turwadi A. Darwito, <sup>e</sup>Tutug Dhanardono, <sup>f</sup>Titik Budiati**

<sup>g</sup>Engineering Physics Departement, FTI  
Sepuluh Nopember Institute of Techology (ITS) Surabaya, Surabaya, Indonesia  
Food Technology Department, State Polytechnic of Jember, Indonesia

[E-Mail: trb@epits.ac.id](mailto:trb@epits.ac.id)

*Abstract*

*Fouling is a deposit inside heat exchanger network in a refinery has been identified as a major problem for efficient energy recovery. This heat exchanger network is also called Crude Preheat Train (CPT). In this paper, Multi Layer Perceptron (MLP) neural networks with Nonlinear Auto Regressive with eXogenous input (MARX) structure is utilised to build the heat exchanger fouling resistant model in refinery CPT and build predictive maintenance support tool based on neural network and HYSYS simulation model. The complexity and nonlinierity of the nature of the heat exchanger fouling characteristics due to changes in crude and product operating conditions, and also crude oil blends in the feed stocks have been captured very accurate by the proposed software. The RMSE is used to indicate the performance of the proposed software. The result shows that the average MOSE of integrated model in predicting outlet temperature of heat a rchanger TH,out and TC,out between the actual and predicted values are determined to be L454 °C and 1.0665 DC, respectively. The integrated model is ready to use in support plant cleaning scheduling optimisation, incorporate with optimi:ation software.*

*Keywords: Modeling, Sinulation, Neural Network, Fouling, Heat Exchanger, Crude Preheat Trai*

**INTRODUCTION**

Fouling in refineries Crude Preheat Train (CPT) is a very serious problem in realization of heat integration that consumes additional energy in the furnace and affects the plant operational cost. Understanding and predicting the fouling behavior in crude preheat train are very imperative to operate and maintain the CPT in an optimal manner, with minimum fouling deposit and operational intervention. However, fouling deposit is largely influenced by the properties of crude or crude blend being processed CPT and operating conditions such as the temperatures and flow rates of crude and products. The fouling deposit mechanism is very complex phenomenon and consequently, it is difficult to develop an accurate fundamental model to predict the heat exchanger fouling rate for different crude blends and different operating conditions in refinery CPT.

Nowday, neural networks have been utilized to build some model and it shown that it capability to approximate nonlinear functions up to high level of accuracy [1]. The technique has been applied in many thermal model and simulation[2][3][4] including the modeling in the steady-state [5] and also modeling in the dynamic behavior of heat exchangers [6][7][8][9]. Several authors have used neural network for an alternative modeling method for the prediction of deposit of fouling [10].

The online fouling deposit detection and estimation through the overall heat transfer coefficient (U) was reported in literature [11]. The neural networks are also robust in

incomplete information than other modeling approaches such as the empirical models and correlations. Fast and accurate fouling deposit rate prediction by using the neural networks model is an added advantage value with less computational load.

Commonly, the neural network fouling deposit prediction system reported in literatures are based on the shell and tube operating conditions and the model not include the properties of the processed fluid inside the heat exchanger [12]. In this paper, Multi Layer Perceptron (MLP) neural networks with Nonlinear Auto Regressive exogenous input (NARX) structure is used to model fouling resistance in a heat exchanger in refinery CPT and it is integrated with HYSYS software, in order to simulate heat exchangers in CPT under clean and fouled conditions.

**METHOD**

The CPT under the present study consists of 10 heat exchangers each of which has multiple shells operating in series and/or parallel modes. The schematic diagram of the CPT is shown in Figure 1.

The operational data from plant historian in the Distributed Control System (DCS) is collected for a period of two years starting from January 2012 - January 2014. The data collected from the plant historian are inlet and outlet temperatures and flow rates of crude and products (heating medium)

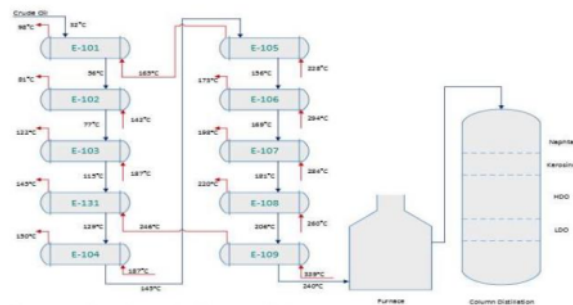

Figure 1. The schematic diagram of the CPTAFAF

A rigorous simulation model of the preheat train that consisting of heat exchangers E-101 to E-109 are developed under the HYSYS environment. The simulation models for individual heat exchangers are setup with the heat exchanger design data as per the design data sheet.

Most of neural network use is feed forward architecture MultiLayer Perceptron (MLP) model architecture. The neural networks have a similar way as low order polynomial in fitting model, through training and validation using set of data. It models are a global approximation of a nonlinear multi-input multi-output function. Commonly, the backpropagation and levenberg marquart learning algorithm are used to optimize the weigh ofthe networks. The different learning algorithms are available in literatures [13][14].

$$y_i = F_i \left[ \sum_{j=1}^{n_h} W_{i,j} \cdot f_j \left( \sum_{l=1}^{n_i} w_{j,l} \phi_l + w_{j,0} \right) + W_{i,0} \right] \quad (1)$$

where  $c_9$  is external input,  $y$  is output,  $n_i$  is number of input in an input layer,  $n_h$  is number of hidden neurons in a hidden layer.  $f$  and  $F$  are activation functions for hidden layer and output layer, respectively.

Almost of the continuous system can be approximated to a acceptable degree of accuracy with the neural network model that consist of the one hidden layer with the hyperbolic tangent activation and linear activation function in the output layer [15-17]. In order to model the dynamics of the fouling deposit resistance, Utilization of the artificial neural networks with NARX structure will be valuable for this purpose.

NARX artificial neural networks structure can be utilized to model the systems based on time-series data. The input variables of the model consist of the present and past values of process inputs and outputs data. The output variables of the model are the fouling resistance, product and crude outlet temperature. Input variables consist of inlet temperatures of crude and product, flow rates,

product properties, crude properties, and also the output variables at past time. The fouling rate for a certain day depends on the rate of fouling on previous day. Hence, the NARX structure can handle time series fouling characteristic. The equations of NARX structure can be expressed as follows:

$$Y^T = j(K, Y_2, \dots, Y_n, U_1, U_2, \dots, U) \quad (2)$$

where  $ra$  is number of output variables and  $in$  is number of input variables.  $Y$  and  $U$  are the output variables and input variables, respectively. The proposed fouling heat exchanger model based on neural networks is shown in Figure 2.

The heat exchanger neural network fouling model with NARX structure has some hidden neurons in a hidden layer, which is trained using Levenberg Marquard learning algorithm for 50 iterations epochs. In order to build a predictive maintenance model, an integrated model between the neural network based fouling resistance model and a rigorous heat exchanger model in HYSYS is needed. The schematic diagram of this integrated model is shown in Figure 3.

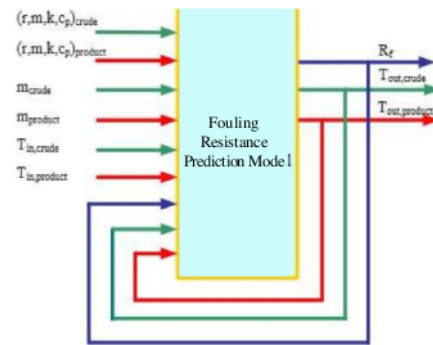

Figure 2. Input output of neural network for the heat exchanger fouling model

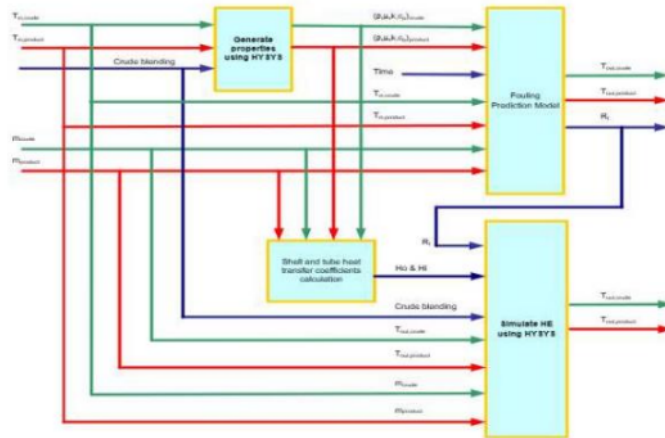

Figure 3. Schematic diagram of integrated model

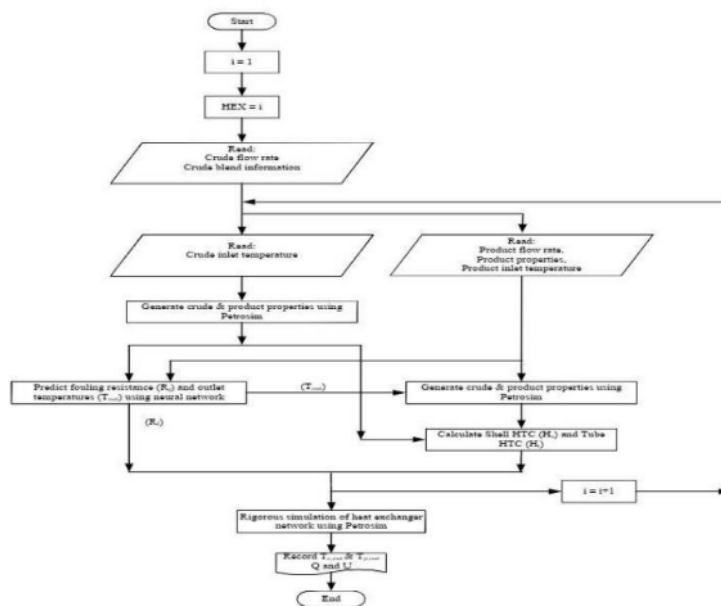

Figure 4. Flowchart of integrated models software

Product and crude properties are predicted using HYSYS from the inlet temperatures of product and crude together with crude blend information. Input variables of neural network model consist of, inlet temperatures of crude and product, flow rates, product properties and crude properties. The output variables of the model are the fouling

resistance, product and crude outlet temperature. In the same time shell and tube heat transfer coefficients are calculated.

The algorithm of heat exchanger models in CPT is shown in Figure 4. The algorithm starts from product and crude average

temperature prediction. Then it estimates the product and crude properties, calculates shell and tube heat transfer coefficient, predicts fouling resistance using neural network. Finally it simulates the rigorous heat exchanger model in HYSYS using information from design data, fouling resistance prediction from neural network model, and calculated shell and tube heat transfer coefficient.

## RESULTS AND ANALYSIS

Data pre-processing consist of removing of missing data, outlier data and data reconciliation are performed. The overall heat

transfer coefficient based on actual operating conditions and for the same operating conditions assuming no fouling on either side (clean condition) are calculated on daily average data for a period of 2 years. From these heat transfer coefficient values the fouling resistance for all heat exchanger is determined.

The uniqueness of this fouling neural network model is that the neural network input data are coming from measurement and estimation, but the fouling resistance as output data of the neural network is calculated using the heat transfer method.

Table 1. Details of NFIR neural network models developed for the heat exchangers in the crude preheat train

Heat Exchanger	No. of best hidden neurons	RMSE, Training			RMSE, Validation		
		$R_f$	$T_{ho}$	$T_{co}$	$R_f$	$T_{ho}$	$T_{co}$
		m <sup>2</sup> K/W	°C	°C	m <sup>2</sup> K/W	°C	°C
E-101	5	2.27E-04	1.545	1.033	3.32E-04	4.194	2.216
E-102	7	3.01E-03	7.870	4.957	1.97E-03	5.827	2.778
E-103	9	1.36E-03	2.187	1.740	2.09E-03	6.157	3.318
E-131	8	1.81E-03	4.005	2.020	1.94E-03	5.618	3.778
E-104	3	4.49E-04	1.514	1.646	1.78E-03	3.285	4.026
E-105	12	1.66E-03	2.389	1.702	4.99E-02	5.728	4.486
E-106	6	3.89E-04	2.090	1.787	1.17E-03	4.153	4.616
E-107	8	6.50E-04	4.209	2.223	7.38E-04	7.459	4.899
E-108	10	7.24E-04	5.250	2.454	7.72E-04	12.204	6.125
E-109	11	1.65E-03	5.511	2.608	5.83E-03	37.645	6.485

Table 2. Details of NARX neural network models developed for the heat exchangers in the crude preheat train

Heat Exchanger	No. of best hidden neurons	RMSE, Training			RMSE, Validation		
		$R_f$	$T_{ho}$	$T_{co}$	$R_f$	$T_{ho}$	$T_{co}$
		m <sup>2</sup> K/W	°C	°C	m <sup>2</sup> K/W	°C	°C
E-101	9	2.43E-06	0.007	0.018	2.16E-05	0.164	0.164
E-102	30	1.53E-06	0.007	0.002	7.66E-05	0.278	0.064
E-103	20	4.60E-06	0.006	0.005	1.81E-04	0.096	0.276
E-131	20	2.19E-05	0.034	0.014	3.04E-04	0.737	0.459
E-104	9	1.25E-05	0.008	0.020	3.03E-04	0.063	0.322
E-105	23	1.37E-05	0.011	0.035	6.55E-05	0.028	0.094
E-106	9	1.05E-05	0.009	0.016	6.12E-04	0.057	0.229
E-107	24	6.62E-07	0.005	0.002	1.66E-05	0.048	0.021
E-108	15	5.39E-06	0.023	0.008	3.02E-04	0.228	0.243
E-109	17	2.69E-06	0.013	0.006	1.59E-04	0.237	0.112



The NN<sup>6</sup> model was trained and validated for different number of neurons in the hidden layer or hidden neuron (HN). The RIVISE for each heat exchanger NFIR and NARX NN models during training and validation are reported in Table 1 and 2, respectively.

The both tables show that the performances of NARX models have better RMSE than NFIR. Hence, the proposed NARX NN model is chosen as final model in this application.

The performance of optimized artificial neural network<sup>2</sup> model in predicting the outputs for the new input data set that not used during the training phase and verified during the validation phase will be described. A new data set from different period of operation was fed as input data to the model and the fouling resistance is predicted. The result RMSE average between the actual and predicted values during training and validation phase are determined to be to be 7.59E-06 and 2.04E-04 m<sup>2</sup>c/W, respectively.

In general, the predicted fouling resistance by the neural networks model is in good agreement with the actual values. The complex nature of the heat exchanger fouling characteristics due to changes in operating conditions and crude oil blends (feed stocks) has been captured reasonably well by the model.

The typical results of the simulation of the CPT under the conditions of fouling are shown in Figure. 5. The differences between the actual and predicted outlet temperatures by the CPT simulation model are show to be very small. The integrated simulation model can be simulated for operation in future and optimum cleaning schedule can be developed well in advance. A summary of RMSE values between the actual and predicted values using the integrated model during the training period and the validation period of neural network are shown in Table 3. The performance of integrated model in predicting the outputs for a new input data set, not used during the training phase, was verified during validation phase. A new data set was fed as input data to the model and the fouling resistance is predicted. The RMSE average of integrated model in predicting TH<sub>out</sub> and TC<sub>out</sub> between the actual and predicted values are determined to be 1.454 °C and 1.0665 °C, respectively

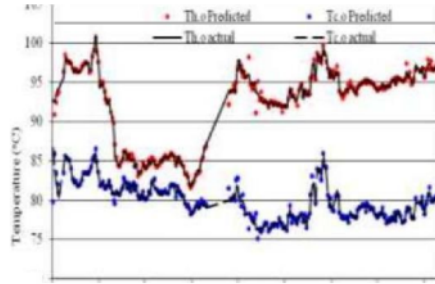

:1-44 :i4IN '214a !AI !him aicp aa1 544.:4

Figure 5. Actual and integrated model prediction for product and crude (Inlet temperature)

Table 3. RMSE values during the simulation of the integrated model

Heat Exchanger	RMSE (°C)	
	$T_{out}$	
E-101	0.8	0.9
E-102	1.1	1.5
E-103	1.1	2.4
E-131	3.5	2.9
E-104	0.3	0.2
E-105	0.1	0.3
E-106	1.8	0.3
E-107	2.2	0.8
E-108	2.6	0.8
E-109	1.0	0.7

CONCLUSION

A neural network model with NARX structure was proposed and developed to describe the complex behavior of heat exchanger fouling in CPT. The RMSE average of NARX neural network, between the actual and predicted values, during training and validation phase are determined to be to be 7.59E-06 and 2.04E-04 m<sup>2</sup>°C/W, respectively. It was observed that the developed integrated model has a good predictive capability. The RMSE average of integrated model in predicting TH<sub>out</sub> and TC<sub>out</sub> between the actual and predicted values are determined to be 1.454 °C and 1.0665 °C, respectively. The integrated model that incorporated with NARX neural network model

is ready to use for plant cleaning scheduling optimization.

#### ACKNOWLEDGMENT

The authors gratefully thank Sepuluh Nopember Institute of Technology (ITS) Surabaya for providing the facilities for conducting this research.

#### REFERENCES

- [1] R. Hecht Nielsen, "Kohnogorov's mapping neural network existence theorem", *Proceedings of the First International Conference on Neural Networks, IEEE*, vol.3, pp. 11-13, 1987.
- [2] M. Sen, and K.T. Yang, *Applications of artificial neural networks and genetic algorithms in thermal engineering*, in: F. Kreith (Ed.), *CRC Handbook of Thermal Engineering*, 2000, pp. 620-661.
- [3] N. Jamali Soufi Amlashi, A. Shahsavari, A. Vahidifar, and M. Nasirian, "Nonlinear System Identification of Laboratory Heat Exchanger Using Artificial Neural Network Model," *International Journal of Electrical and Computer Engineering (IJECE)*, vol. 3, pp. 118-128.
- [4] N. Shadaksharappa, "Optimum Generation Scheduling for Thermal Power Plants using Artificial Neural Network," *International Journal of Electrical and Computer Engineering (IJECE)*, vol. 1, pp. 134-139.
- [5] G. Diaz, M. Sen, K.T. Yang, R.L. and McClain, "Simulation of heat exchanger performance by artificial neural networks", *Int. J. HVAC and R Res.*, vol.5 (3), pp. 195-208, 1999.
- [6] G. Diaz, M. Sen, K.T. Yang, R.L. and McClain, "Use of artificial neural networks for temperature control", *Proceedings of the Fourth ISHMT/ASME Heat and Mass Transfer Conference, Purse, India*, 2000.
- [7] M. Ayoubi, "Dynamic multi-layer perceptron networks: application to the nonlinear identification and predictive control of a heat exchanger", *Applications of Neural Adaptive Control Technology, World Scientific series in Robotics and Intelligent Systems*, vol. 17, pp. 205-230, 1997.
- [8] S. Bittanti, and L. Piroddi, "Nonlinear identification and control of a heat exchanger: a neural network approach", *J. Franklin Inst.*, vol. 334B ( 1), pp. 135-153, 1997.
- [9] N. Jamali Soufi Amlashi, A. Shahsavari, A. Vahidifar, and M. Nasirian, "Nonlinear System Identification of Laboratory Heat Exchanger Using Artificial Neural Network Model," *International Journal of Electrical and Computer Engineering (IJECE)*, vol. 3, pp. 118-128.
- [10] Riverol, and V. Napolitano, "Estimation of fouling in a plate heat exchanger through the application of neural networks", *J Chem Technol Biotechnol*, vol. 80, pp, 594-600, 2005.
- [11] S. Lalot, and S. Lecoeuche, "Online-fouling detection in electrical circulation heaters using neural networks", *International Journal of Heat and Mass Transfer*, vol. 46, pp 2445-2458, 2000.
- [12] V.R. Radhakrishnan, M. Ramasamy, H. Zabiri, V. Do Thanh, N.M. Tallir, H. Mukhtar, M.R. Hamdi, and N. Ramli, "Heat exchanger fouling model and preventive maintenance scheduling tools", *Applied Thermal Engineering*, vol. 27, pp. 2791-2802, 2007.
- [13] M. Norgaad, N. Poulsen, and L. Hansen, *Neural Networks for Modeling and Control of Dynamic Systems*, Springer-Verlag, London. 2000.
- [14] S. Haykin, *Neural network — a comprehensive foundation*, Prentice Hall Inc, New Jersey, 1999.
- [15] G. Cybenko "Approximation by superpositions of a sigmoidal function, *Mathematics of Control, Signal and Systems*, Vol. 2 No. 4, pp. 303-314, 1989.



- [16] G. Shetty, S. and Chellam, 'Predicting membrane fouling during municipal drinking water nanofiltration using artificial neural networks', *Journal of Membrane Science*, pp. 69-86, 2003.
- [17] T. Kathirvalavakumar, and P. Thangavela. "Modified backpropagation train\* algorithm for feedforward neural networks", *Neural Processing Letters*, vol. 23, pp. 111-119, 2006,

# MODELLING AND SIMULATION OF INDUSTRIAL HEAT EXCHANGER NETWORKS UNDER FOULING CONDITION USING INTEGRATED NEURAL NETWORK AND HYSYS

---

## ORIGINALITY REPORT

---

10%

SIMILARITY INDEX

3%

INTERNET SOURCES

11%

PUBLICATIONS

0%

STUDENT PAPERS

---

## PRIMARY SOURCES

---

- 1 Nasser Mohamed Ramli, Mohd Azlan Hussain, Badrul Mohamed Jan. "Multivariable control of a debutanizer column using equation based artificial neural network model inverse control strategies", Neurocomputing, 2016  
Publication 3%
  - 2 V.R. Radhakrishnan, M. Ramasamy, H. Zabiri, V. Do Thanh, N.M. Tahir, H. Mukhtar, M.R. Hamdi, N. Ramli. "Heat exchanger fouling model and preventive maintenance scheduling tool", Applied Thermal Engineering, 2007  
Publication 2%
  - 3 Nourddine Khentout, Giovanni Magrotti. "Fault supervision of nuclear research reactor systems using artificial neural networks: A review with results", Annals of Nuclear Energy, 2023  
Publication 1%
-

4

Raqeab H. Rajab, Hussain H. Ahmad. "Analysis of Thermosiphon Heat Pipe Performance Using an Artificial Neural Network", Journal of The Institution of Engineers (India): Series C, 2021

Publication

---

1 %

5

C Riverol. "Estimation of fouling in a plate heat exchanger through the application of neural networks", Journal of Chemical Technology & Biotechnology, 05/2005

Publication

---

1 %

6

Navvab Kashani, Moein, Javad Aminian, Shahrokh Shahhosseini, and Mohammad Farrokhi. "Dynamic crude oil fouling prediction in industrial preheaters using optimized ANN based moving window technique", Chemical Engineering Research and Design, 2012.

Publication

---

1 %

7

El Mehdi Laadissi, Anas El Filali, Malika Zazi. "A Nonlinear TSNN Based Model of a Lead Acid Battery", Bulletin of Electrical Engineering and Informatics, 2018

Publication

---

1 %

8

Lalrinpuia Tlau, Surender Ontela. "Entropy analysis of hybrid nanofluid flow in a porous medium with variable permeability

1 %

# considering isothermal/isoflux conditions", Chinese Journal of Physics, 2022

Publication

---

---

Exclude quotes      On

Exclude matches      < 1%

Exclude bibliography      On