

Portable Device for Monitoring System in Network Culture Laboratory based on IoT

by Dyah Nuning Erawati

Submission date: 04-Feb-2022 01:55PM (UTC+0700)

Submission ID: 1754728019

File name: Beni_dkk_ProSIDing_Icofa_2021.pdf (6.52M)

Word count: 2933

Character count: 15726



Portable Device for Monitoring System in Network Culture Laboratory based on IoT

B Widiawan^{1*}, Djenal², D N Erawati², R Firgiyanto², A P Anugro¹

¹Department of Information Technology, Politeknik Negeri Jember, Indonesia

²Department of Agriculture Production, Politeknik Negeri Jember, Indonesia

*Email: beni@polije.ac.id

Abstract. Tissue culture is one of the technological developments in the field of agricultural production. This technique is one way of vegetative nurseries to produce ready-to-plant seedlings. The benefits of plant propagation by tissue culture include reproducing pantogen-free plants in large numbers and in a relatively short time. However, in plant propagation by tissue culture it is necessary to pay attention to the factors that affect its success, for example environmental conditions. Environmental condition factors consist of irradiation intensity, temperature and humidity. The intensity of lighting affects the photomorphogenesis process of the explants, while the temperature affects the formation of plant organs and the unstable humidity can make the explants and plantlets grow abnormally. In the Tissue Culture which is carried out at the Laboratory of the Department of Agricultural Production, the State Polytechnic of Jember, also often finds culture failure or it is called kontam (mushroom culture / rotten culture / dead culture) due to the influence of an uncontrolled environment. Manual monitoring activities require more effort and time, and the results obtained are not entirely effective. Based on these problems, this study designed a web system that can monitor temperature, humidity, and light intensity as well as remote control of tissue culture rack lighting based on Microcontrollers and Computer Networks. This system utilizes trending technology, namely the Internet of Things (IoT) and cloud computing. The internet of things allows the results of sensor readings to the temperature, humidity and light intensity levels of the tissue culture room to be accessed by the website. In addition, it also allows the website to adjust the brightness of the lighting according to the needs of the plants. In internet of things communication in this study, the compilers used the MQTT (Message Queuing Telemetry Transport) protocol which has the advantage of being able to run on small bandwidthIntroduction.

1. Introduction

Tissue culture is one of the technological developments in the field of agricultural and food production. This technique is one of the vegetative nurseries in producing ready-to-plant seedlings because each plant cell has the ability to divide or multiply to form new individuals (tettipotency) [1]. Plant propagation with tissue culture is useful for reproducing pantogen-free plants in large numbers and in a relatively short time, in contrast to conventional plant propagation which is considered slow [2]. [3] stated that the advantages of plant propagation through tissue culture are:

- Does not require a large space because it is done on a culture bottle.
- Free of disease, pests, and viruses because it is carried out in aseptic conditions.



- The time for propagation is fast and unlimited.
- It doesn't depend on the season or climate.
- The mother plant can be stored in vitro so it does not require maintenance in the field.
- Save time, effort and cost.
- The resulting seedlings have roots (plantlets), so they can quickly grow in the field.

However, plant propagation by tissue culture needs to pay attention to the factors that influence the success of the nursery, one of which is environmental conditions. Environmental condition factors consist of irradiation intensity, temperature and humidity. Light intensity affects the photomorphogenesis process of explants, while temperature affects the formation of plant organs and unstable humidity can make explants and plantlets grow abnormally [4].

In the Tissue Culture Laboratory of the Department of Agricultural Production, Jember State Polytechnic also often finds culture failure or it is called contamination (mushroom culture / rotten culture / dead culture). Even in every block of tissue culture shelves there are cultures that die and don't grow. Based on the results of interviews with the head of the laboratory, contaminants can occur due to fungi and the unstable lighting of the tissue culture room. Moreover, the need for irradiating each type of plant in the tissue culture block is different. These different needs also make laboratory staff have to frequently visit the culture room to monitor the temperature, humidity, and irradiation intensity of each culture block. Manual monitoring activities require more effort and time, and the results are not fully effective.

Based on these problems, this study designed a web system that can monitor temperature, humidity, and light intensity as well as remotely control tissue culture rack lighting based on Microcontrollers and Wireless Sensor Networks[4][5]. This system utilizes trending technologies, namely the Internet of Things (IoT) and cloud computing [6]. Internet of things allows the results of sensor readings to the level of temperature, humidity and light intensity of tissue culture space can be accessed by the website [7]. In addition, it also allows the website to adjust the brightness of the lighting according to the needs of the plants. In internet of things communication in this study, the compilers used the MQTT (Message Queuing Telemetry Transport) protocol [8] which has the advantage of being able to run on a small bandwidth. The use of cloud computing services on systems designed by compilers is an attempt to allow access to resources and applications from anywhere via the internet network. All data is processed and stored in the cloud, which can also be accessed easily by users. In this case, the tissue culture laboratory conditions can be monitored and controlled[9] from anywhere without having to come to the location, so as to save time and effort in the process of tissue culture nurseries.

Internet of Things (IoT) is a concept of expanding the benefits of internet connectivity that is connected continuously to meet human needs. Apart from sharing data, IoT allows data transfer over the internet without human-to-human interaction, which aims for machine-to-machine connectivity[10]. The internet of things has fundamental characteristics, namely:

- Interconnectivity: The interconnectedness of the global information and communication infrastructure.
- Things-related service: IoT is able to provide services related to matters within these limitations, such as privacy protection and semantic consistency between physical objects and related virtual things. The goal is to provide services related to matters within its boundaries, both technology in the physical world and in the information world to change.
- Heterogeneity: IoT devices are heterogeneous or different based on different hardware platforms and networks. They can interact with other devices or service platforms over different networks.
- Dynamic changes: The state of the device dynamically changing, connected and/or disconnected as well as the context of the device including location and speed. In addition, the number of devices can also change dynamically.



- **Enormous scale:** The number of devices that are required to be managed and that communicate with each other is at least greater than the number of devices connected to the internet. What is more important is the management of the data generated and their interpretation for application purposes.

1.1. Hardware Design

The prototype case is made using 3D printer technology. The prototype is designed with a size of 4x4x20cm. The device consists of a sensor and controller box frame at the top, and a battery box at the bottom. The battery part is designed to be detached when recharging. The box design is designed using CAD which is then converted to *.stl format. Figure 1 is the chassis design used for the monitoring device. The electronic circuit consists of a power circuit, a microcontroller shield, and a series of sensors. The stage of making electronic circuits begins with designing the PCB layout according to the system block diagram that has been made. Figure 2 is a system block diagram of the device created.

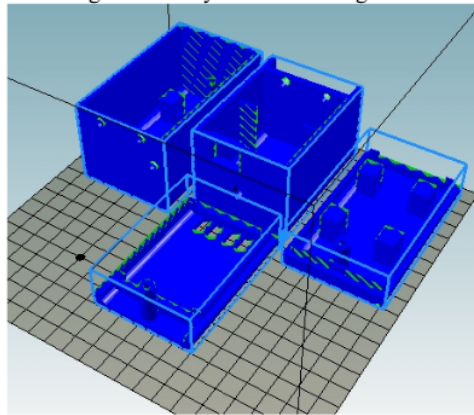

Figure 1. Chassis design used for the monitoring device

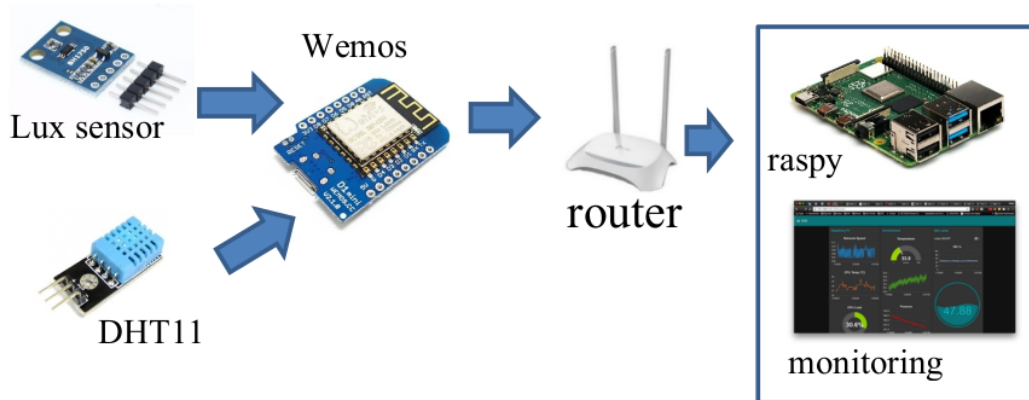

Figure 2. System block diagram of the device created

1.2. Software Design

The website is built using node-red software that has been installed on the cloud so that when building the website the computer / laptop used must be connected to the internet and access the IP cloud. The



way to access nodered is to use an IP address with port 1880. Nodered is installed on the cloud server so that the access method uses the IP address of the server, namely 45.32.124.242. Development of a nodered website begins with structured connection of nodes. Nodered website developers must manage each node used. The nodes are configured with settings and some scripts in them. The script for this nodered uses the javascript programming language. At the planning stage, the website is designed with four website pages so that there are 4 (four) flows in the nodered website development. Figure 3 is a programming flowchart on the raspberry pi server using node-red.

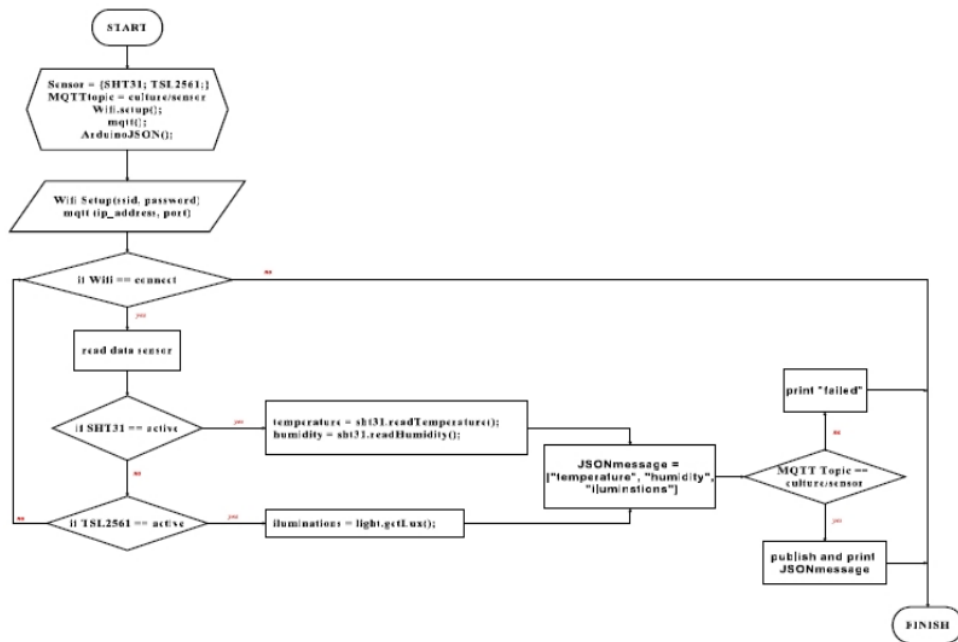

Figure 3. The programming flowchart on the raspberry pi server using node-red

The second is programming the Arduino IDE for microcontrollers. Wemos D1 Mini is used to access temperature, humidity and light intensity sensor data and then send it to the raspberry via a wifi network. Data transmission is carried out per 10 minutes. The programming flowchart for the microcontroller is shown in Figure 4.

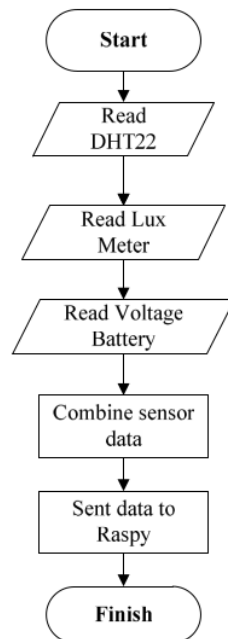

Figure 4. The programming flowchart for the microcontroller

2. Result and Discussion

2.1. System Realization

Power for the system using 2 batteries 85760 arranged in parallel. By using the balancer module, the battery can be recharged using a 5v usb charger. In addition to the electronic box which consists of several circuits, there are other parts that are related to and are still part of the electronic circuit, namely the sensor circuit. A sensor circuit like this consists of two slots as a place to place the sensor. This sensor circuit is connected directly with a cable to the i2c pin (SDA / SCL) of the microcontroller. The PCB design used in the device is shown in Figure 5. The battery box and electronic circuit are designed separately to make recharging the device easier. The sensor box is equipped with an indicator LED as a sign that the sensor is working or dead. Figure 6 is the result of the form of the device used for the monitoring system.

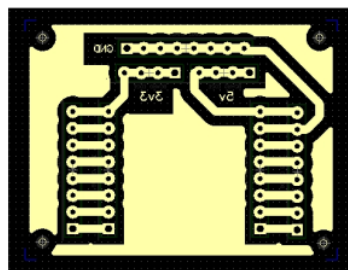

Figure 5. Design of Wemos D1 Mini PCB Shield



Figure 6. The form of the device used for the monitoring system.

In accordance with the planning stage for software, the website is designed with four website pages so that there are 4 (four) flows in the nodered website development. A series of nodered nodes that are made to design a website is described in Figure 7. The home menu flow contains the subscribe mqtt node which functions as a receiver for sensor data published by the microcontroller. This node is configured with the appropriate topic name in the Arduino program embedded in the microcontroller. In addition, there are output nodes that are used to display the data received and processed so that it becomes information that is easily understood by users. Output nodes can be gauge widget, chart, text, and template widget node for creating table views. The node configuration on the home menu is the main configuration for getting data to be stored in the database with the help of the database node so that the stored data can be used in data processing in other menus.

A series of nodes configured in such a way as to produce a website design that can be accessed by typing "IP_Address: port / ui" (45.32.124.242:1880/ui) in the browser url tab. This illumination standard is displayed with the aim of making it easier for users to compare the current level of illumination with the appropriate or different standards so that they can quickly perform treatment. At the bottom of the home menu there is a monitoring and controlling history table which can always be updated to find out details of changes in environmental conditions and control activities that have recently occurred.

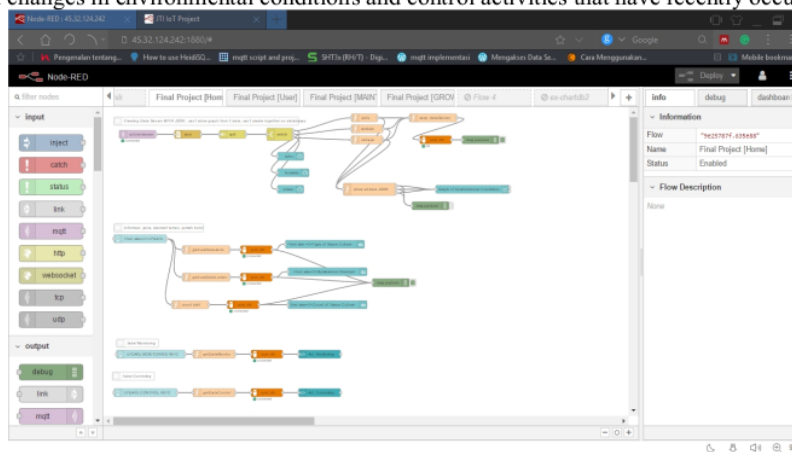

Figure 7. A series of nodered nodes that are created to design a website



2.2. Testing result

Testing the accuracy of sensor readings is done by comparing the sensor reading value with the value shown by the measuring instrument. The measuring instrument used is the environment meter. Based on the test table 1 and 2 shows that the sensor readings of the three parameters, namely temperature, humidity, and illumination are quite accurate with a reading value that is not much different from the reading by the measuring instrument. The percentage error of the average temperature reading is 0.03%, the average humidity reading is 0.02%, and the average illumination reading is 0.07%.

Table 1. The sensor readings of the three parameters, namely temperature, humidity, and illumination

No	Temperatur (°C)			Humidity (%RH)			Iuminasi (Lux)				
	Sensor	Alat ukur	%error	Sensor	Alat ukur	%error	Sensor	Alat ukur	%error		
1	30,48	31,3	0,03	77,10	76,2	0,01	201,89	165	0,18		
2	30,48	31,3	0,03	77,29	75,2	0,03	308,28	265	0,14		
3	30,47	31,5	0,03	76,79	76,6	0,00	388,86	403	0,04		
4	30,51	31,7	0,04	77,33	75,5	0,02	503,22	442	0,12		
5	30,52	31,9	0,04	77,09	74,3	0,04	608,14	608	0,00		
6	30,54	31,7	0,04	77,08	74,1	0,04	703,14	683	0,03		
7	30,57	31,5	0,03	77,14	75	0,03	797,6	806	0,01		
8	30,55	31,4	0,03	76,28	74,8	0,02	900,04	885	0,02		
9	30,55	31,4	0,03	76,14	74,4	0,02	1000,48	929	0,07		
10	30,52	31,3	0,02	76,11	74,5	0,02	1099,84	1034	0,06		
Rata-rata error			0,03	Rata-rata error			0,02	Rata-rata error			0,07

Furthermore, realtime testing of sensor readings is carried out. This test aims to determine the length of time required to transmit data from the sensor to the website using the MQTT communication protocol. Figure 8 is a display when the monitoring application is run.

Table 2. Sensor data transmission time

Data ke-	Waktu Transmisi Data Sensor		
	Transmisi Time	Receive Time	Range Time
1	00:44:56.547	00:44:55.397	00:00:01:150
2	00:44:58.556	00:44:57.407	00:00:01:149
3	00:45:00.562	00:44:59.392	00:00:01:170
4	00:45:02.590	00:45:01.427	00:00:01:163
5	00:45:04.581	00:45:03.427	00:00:01:154
6	00:45:06.603	00:45:05.427	00:00:01:176
7	00:45:08.622	00:45:07.447	00:00:01:175
8	00:45:10.625	00:45:09.447	00:00:01:178
9	00:45:12.656	00:45:11.467	00:00:01:189
10	00:45:14.635	00:45:13.487	00:00:01:148

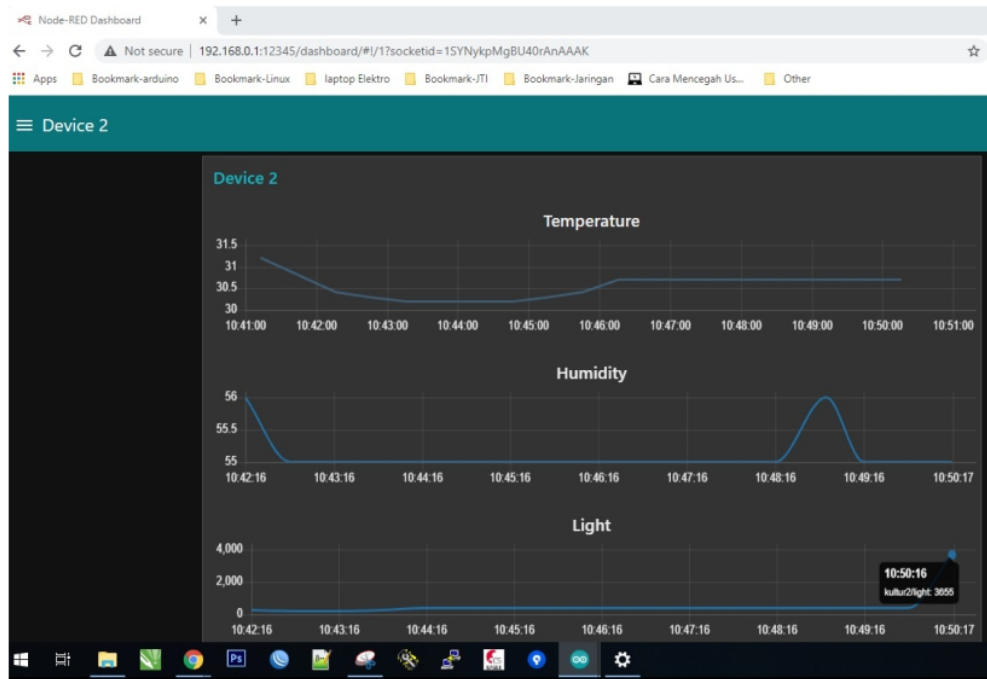

Figure 8. Display when the monitoring application is run

Based on the test, the percentage of monitoring system error is very minimal at 0.009%. For the precision of illumination, there is a TSL2561 sensor calibration process to adjust the brightness level of a given lamp with the current lighting conditions to match the standards inputted by the user. The fastest calibration time is +14 seconds and the slowest is +54 seconds. Based on the test, the lighting level other than the control lights in the room does not really matter.

3. Conclusion

The web-based monitoring and control tool has been successfully designed in prototype form. Device testing has been carried out with the end result that all website features are successfully running according to design. Sensor readings can be said to be accurate with a very small percentage error value, namely 0.03% for the temperature reading, 0.02% for the humidity reading, and 0.07% for the illumination reading. The data transmission speed between the software and hardware is quite fast, which is +1 second for sending sensor data to the website and + 1-2 seconds for the standard control action of the website's illumination against the lighting.

1

Acknowledgment

The authors would like to acknowledge the financial support of this work by grants from PNPB 2020, State Polytechnic of Jember. The author also thanked the P3M and Information Technology Department, State Polytechnic of Jember, which has provided support and assistance in completing this research.

References

- [1] Bayuntoro J T 2016 *Prosiding Seminar Nasional dan Entrepreneurship III Sains Terapan* (Semarang (ID): Program Studi Pendidikan Biologi FPMIPATI Universitas PGRI Semarang) p 522 – 527.
- [2] Zulkarnain 2011 *Kultur Jaringan Tanaman* (Jakarta : Sinar Grafika Offset)



- [3] Danita M, Mathew B, Shereen N, Sharon N and J Paul J J, 2018 *Second International Conference on Intelligent Computing and Control Systems (ICICCS)* (Madurai: India) p 1933-1937
- [4] Etikasari B, Husin, Kautsar S, Riskiawan H Y and Setyohadi D P S 2020 *IOP Conf. Ser.: Earth Environ. Sci.* **411** 012061. DOI:10.1088/1755-1315/411/1/012061
- [5] Setyohadi D P S, Riskiawan, H Y, Kautsar S and Destarianto P 2018 *IOP Conf. Ser.: Earth Environ. Sci.* **207**, 012058. doi:10.1088/1755-1315/207/1/012058
- [6] Kibria M G, Ali S, Jarwar M A and Chong I 2017 *International Conference on Information and Communication Technology Convergence (ICTC) (Jeju Iland: KICS with the technical co-sponsorship of IEEE Communications Society and IEICE Communications Society)* p 29-31
- [7] Syafarinda Y, Akhadin F, Fitri Z E, Yogiswara, Widiawan B, and Rosdiana E 2018 *IOP Conf. Ser.: Earth Environ. Sci.* **207**, 012059. doi:10.1088/1755-1315/207/1/012059
- [8] Saputra G Y, Afrizal A D, Mahfud F K R, Pribadi F A and Pamungkas F J 2017 *J. Informatika Mulawarman* **12**: 69 – 75.
- [9] Fuady G M , Turoobi A H, Majdi M N, Syaiin M, Adhitya R Y, Rachman I and Soelistijono R T 2017 *International Symposium on Electronics and Smart Devices (ISESD)*. doi:10.1109/isesd.2017.8253303
- [10] Patel K K and Patel S M 2016 *International Journal of Engineering Science and Computing* **6** p 6122 – 6131
- [11] Purwati R D and Sudjindro. 2004. *Peluang Perbanyak Bibit melalui Kultur Jaringan untuk Mendukung Pengembangan Rami* (Malang: Balai Penelitian Tanaman Tembakau dan Serat) p 43 – 48
- [12] Widiawan B, Triwidiarto C, Kautsar S and Firgiyanto R 2020 *IOP Conf. Ser.: Earth Environ. Sci.* **411** 012058. doi:10.1088/1755-1315/411/1/012058
- [13] Saputra L K P and Lukito Y 2017 *International Conference on Smart Cities, Automation & Intelligent Computing Systems (ICON-SONICS)* (Yogyakarta: Indonesia) p 126-130.
- [14] Prayogo S S, Mukhlis Y and Yakti B K 2019 *Fourth International Conference on Informatics and Computing (ICIC)* (Semarang: Indonesia) 1-5.

Portable Device for Monitoring System in Network Culture Laboratory based on IoT

ORIGINALITY REPORT

11%

SIMILARITY INDEX

6%

INTERNET SOURCES

10%

PUBLICATIONS

6%

STUDENT PAPERS

PRIMARY SOURCES

- 1 P Destarianto, A Bakri, R T Hertamawati, A L Suryana. "Development of integrated swab chamber for drive thru Covid19 test system", IOP Conference Series: Earth and Environmental Science, 2021
Publication 4%
- 2 Submitted to Anglia Ruskin University
Student Paper 4%
- 3 0-www-crossref-
org.pugwash.lib.warwick.ac.uk
Internet Source 2%
- 4 Rachmad Andri Atmoko, Hendra Yufit Riskiawan, Dwi Putro Sarwo Setyohadi, Syamsiar Kautsar. "The online monitoring system of toxic gas levels in the Ijen Mountain area", AIP Publishing, 2020
Publication 2%

Exclude quotes On

Exclude bibliography On

Exclude matches < 2%